

Zeta Rev

EN

Installation, use and maintenance manual

19-02-2021



THANK YOU

Thank you for choosing our product.

It is the result of many years' experience and careful design and has been built with first-class quality materials and advanced technologies.

Declaration or certificate of conformity also guarantees that the equipment meets the requirements of the European Machinery Safety Directive.

The quality level is constantly monitored, and therefore our products are synonymous with Safety, Quality and Reliability.

Changes considered necessary for product improvement may be made to the stated data at any time without any obligation to give prior notice.

Thank you again



Read this manual carefully before installing, testing or starting this unit.

Give this manual and all complementary documentation to the operator of the system who will be responsible for keeping them so they are always available if needed.



The images and drawings contained herein are examples only.

Contents

1	Introduction	6
1.1	Conformity	6
1.2	Description	6
1.2.1	<i>Symbols</i>	6
1.2.2	<i>Labels</i>	7
2	Safety	8
2.1	General safety precautions	8
2.1.1	<i>Discharge of the safety valves</i>	9
2.1.2	<i>Emergency stop</i>	9
2.2	Basic rules	10
2.2.1	<i>Water flow rate at the heat exchangers</i>	11
2.2.2	<i>Water composition</i>	11
2.2.3	<i>Minimum water content in the system</i>	12
2.2.4	<i>Installing the flow switch</i>	13
2.2.5	<i>Unit operating in heat pump mode</i>	13
2.2.6	<i>Operation with water to the evaporator at low temperature</i>	14
2.2.7	<i>Operation in heat pump mode with low temperature water</i>	14
2.2.8	<i>Hydraulic connection to the heat recuperator (DC option)</i>	15
2.2.9	<i>Hydraulic connection to the desuperheater (DS option)</i>	16
2.2.10	<i>Condensate drain (only for heat pump units)</i>	17
2.2.11	<i>Refrigerant leak detector</i>	18
2.3	Noise	19
2.4	Residual risks	19
2.5	Safety information on the refrigerant fluid	20
2.5.1	<i>Hazards and health consequences</i>	20
3	Receiving the product and storage	21
3.1	Reception	21
3.2	Transport	21
3.3	Handling	22
3.4	Storage	24
4	Ecodesign conformity	25
4.1	Documentation supplied with the product	25
4.1.1	<i>Units conforming to all EC requirements including the Ecodesign Directive</i>	25
4.1.2	<i>Units exempt from the Ecodesign Directive and in general conforming to all EC requirements</i>	25
4.1.3	<i>Partly completed machine</i>	26
4.1.4	<i>Attached Documents envisaged with regard to the type of unit</i>	26
4.1.5	<i>Efficiency parameters required for conformity</i>	26
4.2	Conformity of the application	27
5	Product description	28

5.1	Intended use	28
5.2	Unintended use	28
5.3	Control and safety devices	29
5.4	Principles of operation	29
5.5	Structure	29
5.6	Specifications	29
5.7	Control panels	30
5.7.1	<i>Parametric control</i>	30
5.7.2	<i>Programmable control</i>	32
5.8	Wiring diagram	32
6	Installation	33
.....		
6.1	Dimensions and weight	33
6.2	Installation site	33
6.3	Installation	34
6.3.1	<i>External positioning</i>	34
6.3.2	<i>Noise attenuation</i>	36
6.3.3	<i>Minimum distances</i>	36
6.4	Hydraulic connections	37
6.5	System components	39
6.5.1	<i>Installation of pressure sensors</i>	39
6.5.2	<i>Installation of temperature sensor</i>	40
6.6	Electrical connections	41
6.7	Refrigeration connections	42
6.7.1	<i>Piping implementation</i>	42
6.7.2	<i>LE version: unit installed at a higher level than the remote exchanger</i>	43
6.7.3	<i>LE version: unit installed at a lower level than the remote exchanger</i>	44
6.7.4	<i>LE/HP version: unit installed at a higher level than the remote exchanger</i>	44
6.7.5	<i>LE/HP version: unit installed at a lower level than the remote exchanger</i>	45
6.8	Expansion valve	45
6.9	Vacuum and refrigerant charge	46
6.10	Topping up with oil	47
7	Commissioning	48
.....		
7.1	Preliminary operations	48
7.1.1	<i>Checking the pre-charge of the expansion vessel</i>	49
7.1.2	<i>Checking the volume of the expansion vessel</i>	50
7.1.3	<i>Preliminary operations for LE and LE/HP units</i>	51
7.1.4	<i>Preliminary operations for the Free Cooling No Glycol circuit</i>	51
7.2	First starting	52

7.2.1	<i>Hydraulic tests</i>	52
7.2.2	<i>Start</i>	52
7.2.3	<i>Functional tests</i>	53
7.3	System testing	54
7.3.1	<i>Flowzer VP</i>	54
7.3.2	<i>Flowzer DT</i>	58
7.3.3	<i>Flowzer VDE</i>	62
7.3.4	<i>Flowzer VD</i>	63
7.3.5	<i>Flowzer VFPP</i>	65
7.3.6	<i>Flowzer VPS</i>	68
7.4	Calibration of safety components	71
7.5	Checks during operation	72
7.6	Alarms and malfunctions	73
7.6.1	<i>General troubleshooting</i>	73
7.7	Temporary stop	75
7.8	Stop for long periods of time	75
8	Maintenance	76
.....		
8.1	Adjustments	76
8.2	External cleaning	77
8.2.1	<i>Cleaning traditional finned coils in Cu/Al</i>	77
8.2.2	<i>Cleaning the microchannel coils</i>	78
8.2.3	<i>Cleaning e-coated microchannel coils</i>	79
8.3	Internal cleaning	80
8.3.1	<i>Cleaning the unit</i>	80
8.3.2	<i>Cleaning the plate heat exchangers</i>	81
8.4	Periodic checks	82
8.5	Unscheduled maintenance	83
8.5.1	<i>Special work</i>	83
9	Decommissioning	84
.....		

1 INTRODUCTION

1.1 Conformity

With regard to relevant regulations and directives, see the declaration of conformity that is an integral part of the manual.

1.2 Description

1.2.1 Symbols

A description of the main symbols used in this manual and on the labels affixed to the unit is given below.



Danger symbol; take extreme care.



Danger symbol; moving mechanical parts.



Danger symbol; live parts.



Warning symbol; important information



Note symbol; suggestions and advice



Danger sign: flammable gas.

1.2.2 Labels

For the constructional features, available models and technical data, please refer to the Technical Catalogue.

The model, serial number, features, power supply voltage and so on are shown on the labels affixed to the unit (the following illustrations are shown only as an example).

LOGO		CE	
[]			
Tipo refrigerante Type réfrigérant Refrigerant type Kältemitteltyp	GWP	IP quadro elettrico IP tableau électrique IP electrical panel IP schaltschrank	Matricola Numéro de série Serial number Seriennummer
[]	[]	[]	[]
Max. Corrente assorbita Max. Courant absorbé Max. Absorbed current Max. Stromaufnahme		Max. Corrente di spunto Max. Courant de démarrage Max. Inrush current Max. Anlaufstrom	
[]		[]	
Tensione-Fasi-Frequenza Tension-Phases-Fréquence Voltage-Phases-Frequency Spannung-Phasen-Frequenz		Tensione circuiti ausiliari Tension circuit auxiliaires Auxiliary circuit voltage Steuerspannung	
[]		[]	
Numero circuiti refrigerante Nombre circuits réfrigérant Refrigerant circuit number Anzahl der Kältekreise		Gruppo Fluido Groupe Fluides Fluid Group Fluidgruppe	
[]		[]	
TS temperatura min/max ramo: TS temperature min/max branche: TS temperature min/max branch: TS temperatur min/max zweig:		PS Press. max refrigerant ramo: PS Press. max réfrigérant branche: PS Press. max refrigerant branch: PS Druck max kältemittel zweig:	
[]		[]	
Press. massima circuito idraulico Press. Maxi circuit hydraulique Max. hydraulic circuit pressure Max. zulässiger Druck im Wassersystem		Data di produzione Date de production Date of manufacture Herstellungsdatum	
[]		[]	
Carica refrigerante per circuito(kg)/Charge réfrigérant par circuit(kg) Refrigerant charge on circuit (kg)/Kältemittel Füllmenge (kg/relauf)(kg)			
C1	C2	C3	C4
[]	[]	[]	[]
TON di CO2 equivalente/TON equivalent CO2/TON of CO2 equivalent/TON CO2-äquivalent			
[]			
Contiene gas fluorurati ad effetto serra disciplinati dal protocollo di Kyoto/Contient des gaz à effet de serre fluorés relevant du protocole de Kyoto/Contains fluorinated greenhouse gases covered by the Kyoto Protocol/Enthält vom Kyoto-Protokoll erfasste fluorierte Treibhausgase.			
Manufactured by VAT IT 02481290282			

LOGO		CE	
Mod. []			
		Ser. nr. []	
Tipo refrigerante - Type réfrigérant - Refrigerant type - Kältemitteltyp []			
Manufactured by VAT IT 02481290282			



The Manufacturer adopts a continuous development policy and, in this perspective, reserves the right to make changes and improvements to the documentation and to the units without prior notice.



The Technical Catalogue, the labels placed directly on the unit and the various diagrams referred to below, must be considered an integral part of this manual.



Do not remove or alter the labels placed on the unit.

2 SAFETY

2.1 General safety precautions

Access to the area around the unit must be prevented by special guarding where this is positioned in a location that is not protected and can be reached by unqualified persons.

The equipment operator is responsible for complying with regulatory obligations.

The equipment operator is the person who has actual control over the technical operation and free access, which means the possibility of monitoring its components and their operation and the possibility of granting access to third parties.

The equipment operator has the power to decide on technical modifications, checks and repairs.

The equipment operator may give instructions to employees or to external companies for carrying out maintenance and repair operations.

Access to the unit must be granted exclusively to technicians authorised by the equipment operator.

The equipment must be installed and maintained or repaired by staff and contractors who hold a relevant certificate issued by a certification body. Within Europe, the certification body must be designated by a member state to certify compliance with the requirements laid down in Regulation (EU) No 517/2014 of the European Parliament and of the Council of 16 April 2014 on fluorinated greenhouse gases and repealing Regulation (EC) No 842/2006 Text with EEA relevance.

Access to the unit requires that the closing panels, where fitted, are removed.

On no account must unqualified personnel be allowed to enter the unit and no one should be allowed to enter before the power to it has been turned off.

The user can interact with the unit only through the control and external OK signals.

Only authorised knowledgeable personnel may access the unit in compliance with safety in the workplace regulations. At European level, refer to Council Directive 89/391/EEC of 12 June 1989 on the introduction of measures to encourage improvements in the health and safety of workers at work.

Also, knowledge and understanding of the manual are indispensable for reducing risks and for improving the health and safety of workers.

The operator who enters the unit must have sufficient knowledge to perform the various activities throughout the technical life of the machine.

The operator must know what to do when faced with possible anomalies, malfunctions or conditions of danger to himself or others, and in any case, he must comply with the following instructions:



Stop the unit immediately by using the emergency device.



Do not do anything that goes beyond your duties and technical knowledge.



Inform the manager immediately and do not take personal initiatives.



Before carrying out any work on the unit, make sure you have turned off the power supply to it. Refer to the section on maintenance work.



In units with capacitors and/or inverters, certain components can remain live for several minutes even after having turned off the main switch.

Wait 10 minutes before working on the electrical parts of the unit.



Circuits supplied from external sources (made with orange cable) can remain live even after the power supply to the unit has been turned off.



Work on the unit only if there is sufficient lighting for the type of work to be carried out.

Failure to comply with the instructions in this manual and any modifications made to the unit without prior written consent, will immediately void the warranty.



The law regulating the use of stratospheric ozone depleting substances prohibits the release of refrigerant gases into the environment and obliges owners to recover and return them to the dealer or take them to special collection centres at the end of their operational life.

The refrigerant contained in the refrigerant circuit is included among the substances subject to special control regulations provided for by law and must therefore be disposed of as indicated above.

Particular care should be taken during maintenance operations in order to reduce refrigerant leaks as much as possible.

2.1.1 Discharge of the safety valves

If present on the refrigerant circuit, installation requirements and/or national regulations lay down that the discharge of the safety valves must be routed to the outside.

The conveying must be done with a pipe whose diameter must be at least that of the valve outlet, and the weight of the pipe must not be borne by the valve.



Always direct the discharge to areas where the jet cannot cause harm to anyone.



Risk of burns following contact with hot and cold parts.

2.1.2 Emergency stop

In case of emergency, an immediate stop is carried out using the red disconnecting switch/master switch on the electrical control panel by turning it to 0. When it is turned to 0, the disconnecting switch turns off the power to the whole unit.



The main disconnect switch/master switch, used to electrically isolate the unit, is also intended for use as an emergency device and it is only in an emergency that it should be used to stop the unit.

Except the case of an emergency stop, the unit must be stopped using its control software.

2.2 Basic rules

All the units are designed and built in compliance with Directive 2014/68/EU of the European Parliament and of the Council of 15 May 2014 on the approximation of the laws of the Member States relating to pressure equipment.

To ensure maximum safety, in order to prevent possible risks, follow the instructions below:

- this product contains pressurised vessels, live components, moving mechanical parts and very hot and cold surfaces that, in certain situations, can pose a risk: all maintenance work must be carried out by skilled personnel equipped with the necessary qualifications in accordance with current regulations. Before carrying out any operation, make sure that the personnel in charge has full knowledge of the documentation supplied with the unit.
- always have a copy of the documentation near the unit.
- The operations indicated in this manual must be integrated with the procedures indicated in the user instruction manuals of the other systems and devices incorporated in the unit. The manuals contain all the necessary information for safely managing the devices and the possible operating modes.
- use suitable protection (gloves, hard hat, protective glasses, safety shoes, etc.) for all maintenance or control operations carried out on the unit.
- Do not wear loose clothing, ties, chains, watches, etc., which can get caught in the moving parts of the unit.
- always use tools and protective equipment in excellent condition.
- The compressors and delivery gas pipes are at high temperature. Therefore, when working in the immediate vicinity, be careful to avoid touching any components of the unit without suitable protection.
- do not work in the discharge trajectory of the safety valves.
- if the units are positioned in unprotected places which can easily be reached by unqualified persons, suitable protection devices must be installed.
- the user must consult the installation and use system manuals, incorporated and attached to this manual.
- there may be potential risks that are not obvious. Warnings and signals are therefore displayed on the unit.
- Do not remove the warnings.

It is expressly forbidden to:

- remove or disable the safety guards;
- tamper with and/or modify, even partially, the safety devices installed on the unit.

If there are alarm warnings and consequent tripping of the safety devices, the user must call in skilled maintenance technicians to fix the problem immediately.



An accident can lead to serious injury or death.

The safety devices must be tested according to the guidelines in this manual.

The manufacturer does not assume any liability for damage/injury to persons, pets or objects arising from the re-use of individual parts of the unit for functions or assembly situations different from the original ones. Tampering with/unauthorised replacement of one or more parts of the unit is prohibited.

The use of accessories, tools or consumables other than those recommended by the Manufacturer relieves the latter from civil and criminal liability.

Deactivation and scrapping of the unit must be carried out only by suitably trained and equipped personnel.



The units do not fall within the scope of Directive 2014/34/EU of the European Parliament and of the Council, of 26 February 2014, on the approximation of the laws of the Member States relating to equipment and protective systems intended for use in potentially explosive atmospheres.

2.2.1 Water flow rate at the heat exchangers

It is necessary to ensure that the water flow rate during operation is no higher than 1.5 times and no lower than 0.5 times the nominal flow rate of the unit stated in the Technical Catalogue.



In any case, refer to the specific Technical Catalogue for the allowed conditions for water flow in and out of the exchangers.

2.2.2 Water composition

Dissolved substances in the water can cause corrosion in the heat exchangers.

It is mandatory to make sure the parameters of the water comply with the following table:

Description	Values
Total hardness	2,0 ÷ 6,0 °f
Langelier index	- 0,4 ÷ 0,4
pH	7,5 ÷ 8,5
Electrical conductivity	10÷500 µS/cm
Organic elements	-
Hydrogen carbonate (HCO ₃ ⁻)	70 ÷ 300 ppm
Sulphates (SO ₄ ²⁻)	< 50 ppm
Hydrogen carbonate / Sulphates (HCO ₃ ⁻ /SO ₄ ²⁻)	> 1
Chlorides (Cl ⁻)	< 50 ppm
Nitrates (NO ₃ ⁻)	< 50 ppm
Hydrogen sulphide (H ₂ S)	< 0,05 ppm
Ammonia (NH ₃)	< 0,05 ppm
Sulphites (SO ₃), free chlorine (Cl ₂)	< 1 ppm
Carbon dioxide (CO ₂)	< 5 ppm
Metal cations	< 0,2 ppm
Manganese ions (Mn ⁺⁺)	< 0,2 ppm
Iron ions (Fe ²⁺ , Fe ³⁺)	< 0,2 ppm
Iron + Manganese	< 0,4 ppm
Phosphates (PO ₄ ³⁻)	< 2 ppm
Oxygen	< 0,1 ppm

ppm = mg/l

The use of water with values above the limits stated in the table will immediately void the warranty.

It is mandatory to include a system for eliminating possible organic substances in the water that could pass through the filter and settle in the heat exchangers, which would lead to malfunctioning and/or breakage over time.

The use of water containing organic substances will immediately void the warranty.

2.2.3 Minimum water content in the system

For correct operation of the unit, it is necessary to ensure a buffering on the system such as to comply with the minimum operating time considering the greater between the minimum OFF time and the minimum ON time.

In short, these contribute to limiting the number of times the compressors are switched on per hour and to preventing undesired deviations from the set point of the delivered water temperature.

The following experimental formula allows the minimum water volume of the system to be calculated:

$$v = \frac{P_{tot}}{N} \cdot 1000 \cdot \frac{\Delta\tau}{\Delta T \cdot \rho \cdot Cp} \cdot Fm + P_{tot} \cdot K_1$$

where

v = Minimum water content of the system [l]

P_{tot} = Total refrigeration capacity [kW]

N = N° of capacity reduction steps

Δτ = Time interval – the greater between minimum OFF time and minimum ON time [s]

ΔT = Allowed differential on the water temperature [°C](unless specified, this is 2.5°C)

ρ = Water density 1000 [kg / ³]

C_p = Specific heat of water 4.186 [kJ / (kg°C)]

F_m = Q factor: experimental factor, different from 1 for some types of unit

K₁ = Experimental multiplying constant depending on the type of compressor

With some terms grouped together, the formula can be rewritten as follows:

$$v = \frac{P_{tot}}{N} \cdot K \cdot Fm + P_{tot} \cdot K_1$$

If the carrying fluid consists of mixtures of water-glycol (ethylene or propylene), the density and specific heat values must consequently be adjusted.

For units with scroll compressor, the constants used in the formula assume the following values:

K [l/kW]	17,2
N	For units without inverter = the number of compressors installed in the unit
	For units with single-compressor inverter = 3
	For units with a dual-compressor inverter (1 inverter cmp + 1 on/off cmp) = 6
	For units with a three-compressor inverter (1 inverter cmp + 2 on/off cmp) = 9
Fm	1
K1	0,25

The constant K considers that the maximum between the minimum ON and OFF time is Δτ=180s.

Larger amounts of water are in any case always preferable, because they allow a smaller number of stops and starts of the compressors, less wear of them and an increase in the efficiency of the system as a consequence of a reduction in the number of transients. It should also be pointed out that, for air-water units working in heat pump mode, the minimum amount of water must consider the need of the unit to carry out defrosting. Having an adequate buffering volume will allow prevention of too high drifts of the delivered water temperature at the end of the defrost cycle.

2.2.4 Installing the flow switch

The units are equipped between the evaporator inlet and outlet with a differential pressure switch. A flow switch, that must be connected by the installer, can be supplied as accessory.

The installed flow switch is provided with a 1" male connector.

The unit must be installed following the arrow that shows the direction of flow.

The installation must be done in a straight section of pipe away from filters, valves, etc. at a distance of at least 5 times the pipe diameter, both upline and downline.

The flow switch is factory calibrated for installation on a horizontal pipe.

The push rod must be in the vertical position.

The connections of the flow switch with the terminal board in the electrical control panel must be made using the common terminal and the terminal that is normally open when there is no water circulation.

Check the terminals provided for the flow switch in the wiring diagram of the unit.

Use a 2 x 1 mm² cable or at most a 2 x 1.5 mm² cable, with diameter between 6 and 9 mm, suitable for installation.

Lock the cable in place with cable ties in the section between the flow switch and the inlet to the electrical control panel.



Refer to the instructions provided with the flow switch to identify the correct set of foils.



Correct flow switch/sensor operation requires that the speed of the fluid flowing through them is within the specified operating limits.

The table below shows the pipe diameters to be used in the system section where the flow switch is to be installed, according to the flow rate.

Hydraulic diameter (inches)	Min. flow rate m ³ /h	Max. flow rate m ³ /h
1"	2,5	3,6
1" 1/4	3,6	6,1
1" 1/2	6,1	9,2
2"	9,2	15,0
2" 1/2	15,0	24,0
3"	24,0	36,0
4"	36,0	60,0
5"	60,0	94,0
6"	94,0	120,0
8"	120,0	240,0
10"	240,0	381,6



Connect the flow switch to the outlet of the user-side heat exchanger indicated in the dimensional diagram.



The Manufacturer declines any and all responsibility for malfunctions due to non-complying installation of the flow switch.

2.2.5 Unit operating in heat pump mode

The performance of units in heat pump operation goes down as the external air temperature falls.

The units can be equipped with anti-freeze heater for heating the exchanger.

This heater starts working with the unit off, when the temperature of the water leaving the evaporator drops below the anti-freeze calibration temperature.

2.2.6 Operation with water to the evaporator at low temperature

With temperatures below 5°C, it is mandatory to work with water and anti-freeze mixtures, and also change the safety devices (anti-freeze, etc.), which must be carried out by qualified authorised personnel or by the manufacturer.

The glycol percentage by weight is determined based on the desired temperature of the chilled water (see table).

Minimum ambient temperature or liquid outlet temperature (°C)	0	-5	-10	-15	-20	-25	-30	-35	-40
Freezing point (°C)	-5	-10	-15	-20	-25	-30	-35	-40	-45
Antifreeze	% by weight								
Ethylene glycol	6	22	30	36	41	46	50	53	56
Propylene glycol	15	25	33	39	44	48	51	54	57



If ambient temperatures are expected to be lower than the freezing point of water, it is essential to use anti-freeze mixtures in the above-mentioned percentages.

2.2.7 Operation in heat pump mode with low temperature water

The standard units are not designed to operate in heat pump mode with water temperatures that are too low (refer to the Technical Catalogue for the limits).

In order to operate below this limit, the unit could require structural modifications.

If required, please contact our company.

2.2.8 Hydraulic connection to the heat recuperator (DC option)

The heat recuperator must be connected to a closed hydraulic circuit.



Constant renewal of water causes limescale to build up in the exchanger, which reduces its efficiency in a short time and makes it unserviceable.

All units equipped with heat recuperator have water temperature control probe on the return from the system.

The microprocessor control enables recovery when necessary, by switching the fans off and starting them again when the water has reached the desired temperature.

If an anomaly occurs at the recovery condenser, the microprocessor control will restart the fans.



It is essential for the water to come in at the connection indicated in the dimensional diagram and with the relevant label on the unit.



A modulating three-way valve that will ensure an incoming water temperature within the operating limits stated in the Technical Catalogue must be installed for correct operation of the unit.

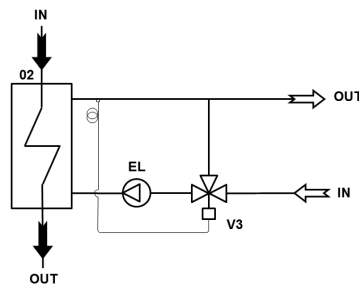

Fig. 1 3-way valve installation layout

02	Heat recuperator
EL	Motor-driven pump
V3	Thermostatic three-way valve

As an alternative to the 3-way modulating valve, it is possible to use a pressure switch valve for each refrigerant circuit that will ensure an average condensing temperature of at least 40°C.

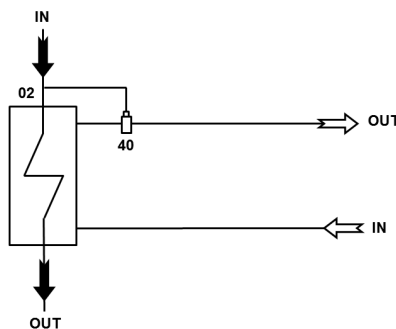

Fig. 2 Pressure switch valve installation layout

02	Heat recuperator
40	Pressure switch valve

2.2.9 Hydraulic connection to the desuperheater (DS option)

The heat desuperheater must be connected to a closed hydraulic circuit.



Constant renewal of water causes limescale to build up in the exchanger, which reduces its efficiency in a short time and makes it unserviceable.

Part of the heat rejected in the condenser can be recovered with a “desuperheater” water heat exchanger.

The desuperheater is installed on the discharge side of the compressors and refrigerant gas always passes through it.

The part of the heat that is not recovered by the desuperheater is rejected in the condenser that always remains active.

The heat recovered through the desuperheater can only be used as an addition to another source.

The main source for the production of heat must guarantee the minimum water temperature for desuperheater operation.



It is essential for the water to come in at the connection indicated in the dimensional diagram and with the relevant label on the unit.



The desuperheater in reversible units can be used both in cooling and in heating mode.



Units set up for reversibility on the chilling cycle require taking specific arrangements to enable use of the desuperheater during operation in heating mode.

Specific arrangements include the following:

- a valve must be installed in the desuperheater circuit;
- the valve must be operated to automatically control the temperature of the input water into the desuperheater;
- the temperature of the input water into the desuperheater must be kept higher than 10 K with respect to the design value of the output water from the heat exchanger, when operating in heating mode.



The client has to provide for the valve, its control device, its installation and setup.



If desuperheater operation is not required during heating mode, or where the input temperature is not controlled, the relevant hydraulic circuit must be shut off.

If a desuperheater is fitted, included in heating mode, whether it is used or not, it has an impact on (i.e. reduces) the thermal power and the max. temperature of the output water.

2.2.10 Condensate drain (only for heat pump units)

As an accessory, all heat pump version units can have a condensate drip tray with drain holes at the base of each condensing/evaporating coil.

If the supplied holes are used to transfer water through pipes, these drain pipes must be prevented from freezing.

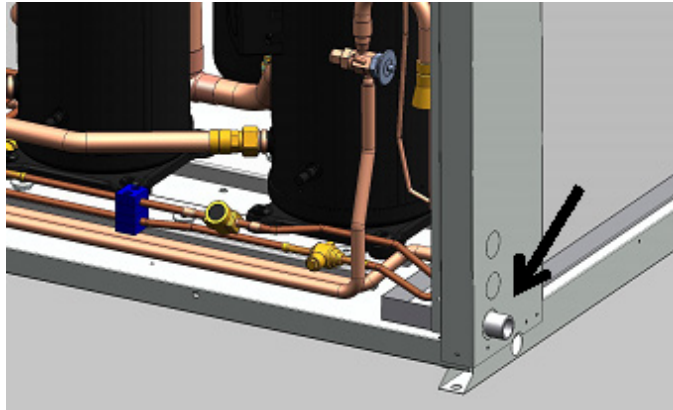

Fig. 3 Position of condensate drain

2.2.11 Refrigerant leak detector

A refrigerant leak detector with semiconductor sensor can be installed on the units.

This device allows immediate detection of refrigerant leaks, with a warning or with stopping of the unit in pump down, depending on how it is managed.

The installation of the device is in line with European F-GAS regulations and USA ASHRAE regulations.

Local regulations may require different calibration values with specific sensor checking and calibration procedures.

The main regulations require a check with tests at least once a year.



Check your local regulations on calibration and the testing requirements.



The alarm contact opens for 5 seconds any time power is cut out and then restored to the sensor. Set a suitable delay in the warning message. Up to 3 minutes are required for the sensor to complete the start-up cycle.



The detector must be tested and/or calibrated by a qualified technician.

To test and calibrate the device, qualified operators must know the rules and regulations laid down by the industrial sector and/or by the country of installation.



In the event of a significant refrigerant leak with prolonged exposure, check the sensor and, if necessary, replace the sensing element.

In any case, the sensing element of the device has a lifetime after which it must be replaced.



For replacement of the sensing device and for other accessories needed for calibration, refer to your customer service centre.

2.3 Noise

The starting of the unit, with activation of its components, emits a noise whose intensity varies depending on the operating level.

The correct location choice and the correct installation prevent the unit causing annoying noise due to resonances, reflections and vibrations.

2.4 Residual risks

The unit uses technical means suitable for protecting people, animals and things against hazards that cannot reasonably be eliminated or sufficiently reduced through design.

The presence of an operator is not required for normal operation of the unit. The change from the "OFF" state to the "ON" state, and vice versa, of the unit can be carried out remotely or through the display, without having to enter areas at risk.

Access restriction is part of correct installation to eliminate residual risks during normal operation.



Removal of the restrictions gives access to cold parts, hot parts and sharp edges.



When the electrical boxes and the electrical control panel are open, live parts can be accessed.

Do not:

- remove or disable the safety guards;
- tamper with and/or modify, even partially, the safety devices installed on the unit.

In heat pump operation, during defrost cycles, the water drips onto the ground when the frost melts off the coils.

If the water is not properly drained, when the ambient temperatures are sub-zero, dangerous sheets of ice are formed.

Limit access to the area to prevent accidents.

2.5 Safety information on the refrigerant fluid

This product contains fluorinated greenhouse gases included in the Kyoto protocol. Do not release these gases into the atmosphere.

Type of refrigerant: R410A

GWP value: 2088. Based on "IPCC Fifth Assessment Report".

GWP is the global warming potential.

The quantity of refrigerant fluid is indicated in the unit's data label. Periodic inspections are necessary to check for refrigerant fluid leaks in accordance with local and/or European regulations.

2.5.1 Hazards and health consequences

If accidentally released, rapid evaporation of the liquid can cause freezing.

In case of contact with the liquid:

- defrost the various part with water;
- remove clothing carefully;
- rinse thoroughly with water.

Contaminated clothing and shoes should be washed before reuse.

High vapour concentrations can cause headaches, dizziness, drowsiness and nausea, and may lead to unconsciousness and cardiac arrhythmia.

If inhaled move the victim to fresh air. Artificial respiration and/or oxygen may be necessary. Call a doctor immediately.

In case of contact with eyes, remove contact lenses. Rinse immediately with plenty of water, holding the eyelids open, for at least 15 minutes.



The safety data sheet drawn up by the producer of the refrigerant can be obtained from the manufacturer of the unit.

3 RECEIVING THE PRODUCT AND STORAGE

3.1 Reception

On receiving the unit, check that it is undamaged, bearing in mind that it left the factory in perfect condition.

Report any signs of damage immediately to the transporter and make a note of these on the Delivery Sheet before signing it.

The relevant sales department or the manufacturer should be informed of the extent of the damage as soon as possible.

The Customer must draw up a written and photographic report concerning any and all significant damage.

Disposal of the packing material is the responsibility of the consignee and must be carried out in compliance with the regulations in force in the country in which it is carried out.

3.2 Transport

The unit is sent from the factory using suitable vehicles, with correct locking in order to prevent any possibility of movement whilst in transit by road that may damage it or cause accidents.

If there is to be trans-shipment to other vehicles to continue the journey, it is essential to adopt all necessary measures for ensuring the correct safety conditions, with regard to the vehicles used and the anchorage, in order to prevent damage.

If the unit is to be transported over uneven roads, the manufacturer must be informed beforehand so that suitable measures can be taken in order to prevent damage to the unit.

If it is to be transported by container, make sure it is correctly anchored.

With reference to road, sea/ocean or air freight, refer to the ADR, IMDG, IATA codes, etc. in place at the time of transport.

Before organising the freight, the Manufacturer shall notify the quantity and type of refrigerant filled in the machine.

3.3 Handling

Before each unit handling operation, check that the lifting capacity of the machinery used is compatible with the weight of the unit.

Handling must be carried out by adequately equipped qualified personnel.



In all lifting operations, make sure the unit is firmly secured in order to prevent accidental falls or overturning.



Lifting must be carried out by qualified and authorised personnel taking the necessary precautions; if carried out incorrectly, lifting can cause serious damage and physical injury.



Do not, under any circumstances, stand or pass under or near the unit when it is lifted off the ground. Use only the lifting system designed and prepared for the unit.

During unloading and positioning of the unit, great care must be taken to prevent sudden or violent manoeuvres, and the components of the unit must not be used as lifting points.

Make sure the machinery and lifting ropes are of suitable size and capacity and strictly follow their operating instructions. Use only equipment that is in excellent working order.

All work on the unit, including unpacking and connections, must be carried out with the unit resting on the ground.

Refer, in any case, to the lifting instructions provided with the unit.

The units are dispatched screwed onto pallets having anti-overturning boards. To unload them from the vehicle, use a forklift truck or a crane.

If a forklift truck is used, insert the forks under the unit on the side where the anti-overturning boards are fixed, with the forks as far apart as possible, until they protrude from the back of the base, and keep the centre of gravity of the unit centred between the forks.

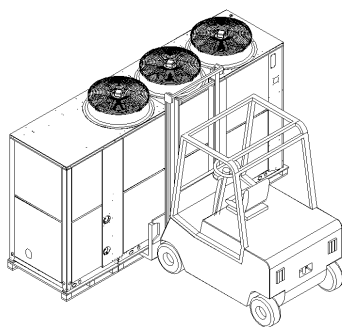

Fig. 4 Lifting with forklift truck

If you are using a crane, sling the unit with slings using suitable lifting tubes (not supplied with the unit) inserted in the slots on the base of the unit.

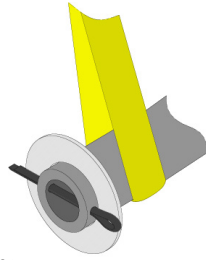

Fig. 5 Detail of hooking the sling to the lifting tube

It is mandatory to use a lifting beam adjusted to the width of the unit in order to ensure lifting stability. Also, suitable protective devices must be placed on the upper edges to prevent the slings from coming into contact with the unit. If the unit is shipped in rigid packaging, this precaution is not necessary.

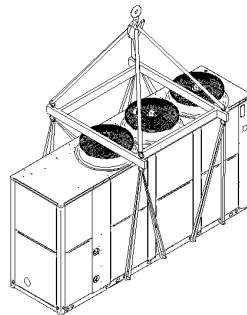

Fig. 6 Lifting with crane

If anti-vibration mounts are installed under the base of the unit, this must be done with the unit raised by no more than 200 mm from the ground and without putting any parts of the body under it.

Before sliding out the pallet, remove the four screws fixing the top board of the pallet to the unit.

If the screws fixing the pallet to the unit are visible through the slotted holes of the base, use a 10 mm spanner to unscrew them.

If the screws are not visible through the slotted holes, they are about 60 centimetres from the corners of the pallet. Use a 13 mm spanner to unscrew them.

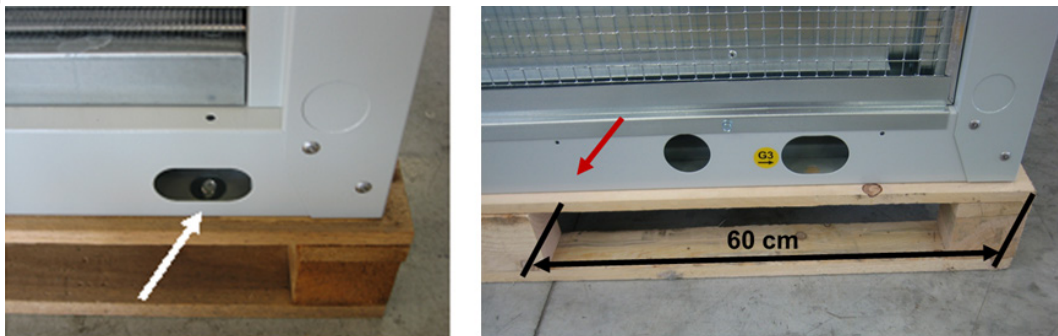

Fig. 7 Special positions of pallet fixing screws

3.4 Storage

There are no special requirements if the unit has to be stored temporarily before installation.

Since these units are intended for outdoor installation, they withstand normal atmospheric conditions without problem.

The unit must be placed on a flat surface that is suitable for bearing its weight, in order to avoid deformation of the structure with consequent possible breakage.

4 ECODESIGN CONFORMITY

4.1 Documentation supplied with the product

Listed below are the documents supplied with the machine according to its type, with particular reference to conformity with Directive 2009/125/EC of the European Parliament and of the Council, of 21 October 2009, regarding the establishment of a framework for drafting specifications for the eco-friendly design of energy-related products, and relevant Regulations (hereinafter "Ecodesign").

These documents may or may not be binding depending on the country of installation.

Conformity of the units with the directives and standards in force in the European Union is broken down into the following cases, with regard to applicability of Ecodesign:

1. Units conforming to all EC requirements including the Ecodesign Directive;
2. Units exempt from the Ecodesign Directive and in general conforming to all EC requirements;
3. Partly completed machine;
4. Units conforming to all EC requirements except for the Ecodesign Directive.

4.1.1 Units conforming to all EC requirements including the Ecodesign Directive

Application of the Ecodesign Directive depends on the type of unit.

The CE marking is present.

The units can be put on the market in any country.

More specifically, they are allowed to be put on the market in member countries of the European Union (hereinafter "EU").

Putting the units on the market in the EU entails installation and running of the unit within this scope.

Putting the units on the market in the EU is bound by the effective dates required by each Regulation.

The EC Declaration of Conformity (hereinafter "EC Declaration") is supplied with the unit:

- irrespective of the destination country;
- according to the relevant Regulation, the EC Declaration is supplemented by one or more attached documents, also called product fiches (hereinafter "Attached Document");
- where envisaged, the Attached Document is always supplied irrespective of the destination country.

Units involved:

- chillers (with or without free-cooling mode);
- reversible heat pumps (cooling / heating), including multifunction units;
- non-reversible heat pumps (heating only) where applicable.

4.1.2 Units exempt from the Ecodesign Directive and in general conforming to all EC requirements

Units for which conformity with the Ecodesign Directive is not necessary.

All the points described in the first paragraph apply, with the exceptions stated below.

The EC Declaration is not accompanied by Attached Documents.

Units involved:

- non-reversible heat pumps (heating only) where applicable with $P_{design} > 400kW$.
- chillers in general used for "Process" applications with water delivery temperature $> 12^{\circ}C$ or between $-8^{\circ}C$ and $+2^{\circ}C$ (extremes excluded).

4.1.3 Partly completed machine

Units for which conformity with the Ecodesign Directive must be related to a 'partly completed machine plus remote heat exchanger' system. Otherwise, the unit conforms to all EC requirements.

All the points described in the first paragraph apply, with the exceptions stated below.

The EC Declaration is not accompanied by Attached Documents

Conformity with the Ecodesign Directive depends on the combination of partly completed machine plus remote heat exchanger and is therefore the responsibility of the person who makes the selection and combination at the installation stage.

Units involved:

- chillers or reversible units with remote source heat exchanger;
- chillers or reversible units with remote user heat exchanger.

4.1.4 Attached Documents envisaged with regard to the type of unit

A table summarising the attached documents with regard to the type of unit is shown below.

Table (a)

Type of unit	Regulation	Supplied Attached Documents, reference parameter	
CE unit	2016/2281	SEER/ η_{sc} LT	
CE unit	2016/2281	SEER/ η_{sc} MT	
CE unit	2016/2281	SEER/ η_{sc} LT	SEPR HT
CE unit	2016/2281	SEER/ η_{sc} MT	SEPR HT
CE unit	2013/813	SCOP/ η_{sh} (1)	Eco-label (2)
CE unit/exempt from Ecode-sign	not applicable	none	
CE partly completed machine	2016/2281 or 2013/813	none	

(1) SCOP/ η_{sh} LT or MT as required by Regulation 2013/813.

(2) Where provided for by Regulation 2013/811, applies to heat pumps with Pdesign <70kW.

4.1.5 Efficiency parameters required for conformity

To avoid ambiguity, this chapter identifies efficiency parameters with the acronyms indicated below.

Regulation 2016/2281 envisages conformity according to the following efficiency parameters:

- η_{sc} low temperature: user-side inlet/outlet temperatures 12/7°C; identified in this document as SEER/ η_{sc} LT;
- η_{sc} medium temperature: user-side inlet/outlet temperatures 23/18°C; identified in this document as SEER/ η_{sc} MT;
- SEPR HT.

Regulation 2013/813 envisages conformity according to the following efficiency parameters:

- η_{sh} low temperature: user-side inlet/outlet temperatures 30/35°C, average climate design conditions; identified in this document as SCOP/ η_{sh} LT;
- η_{sh} medium temperature: user-side inlet/outlet temperatures 47/55°C, Average climate design conditions; identified in this document as SCOP/ η_{sh} MT; this applies as regards models that can operate with delivery temperature $\geq 52^\circ\text{C}$ at a source temperature of -7°C db/ -8°C wb (air-water unit) (10°C inlet for water unit) in the aforesaid climate profile.

For each unit, the composition of the Attached Document(s) is predefined and comes under one of the cases in table (a); therefore, more specifically:

- if the type of unit and/or the expected operating condition are exempt from conformity, the EC Declaration will in any case be accompanied by Attached Document(s) according to table (a);
- in any case, the operating temperatures specified when ordering do NOT determine the type of Attached Document supplied.

4.2 Conformity of the application

The applications allowed as regards the documentation supplied with the unit are indicated below. This applies only in the case of units intended for installation and operation in the European Union.



The customer is required to select the unit with regard to the expected operating condition and the Ecodesign conformity required for that condition.

The documentation available during pre-sale enables the unit to be selected, ordered and purchased correctly for this purpose.

Table (b) indicates the type of conformity required according to the operating condition.

Conformity is to be verified during selection/pre-sale and will be certified by the Attached Document supplied with the unit.

The applications are defined by the Regulations as follows:

1. "Comfort" = application intended for the thermal comfort of people;
2. "Process" = application intended for cooling an appliance or a refrigeration system, whose aim is not to ensure cooling of a room for the thermal comfort of people.

A table summarising the Ecodesign Conformity required with regard to operating condition is shown below.

Table (b)

Operation / Water delivery temperature (LWT cooling), °C	Conformity	Notes
1) Comfort, cooling-only	< 18	SEER/ηsc LT (1)
2) Comfort, cooling-only	≥ 18	SEER/ηsc MT
3) Process, cooling-only	+2 ≤ LWT ≤ 12	SEPR HT
4) Process, cooling-only	> 12	none
5) Process, cooling-only	-8 < LWT < 2	none

(1) - All the more so, SEER/ηsc MT conformity is also valid.



In the "Process, cooling only" case with delivery temperature between -8°C and +2°C (point 5 of table (b)), no type of conformity is required if the unit can operate only at delivery temperatures strictly higher than -8°C.

Operation / Unit: type and Pdesign, kW	Conformity
6) Comfort, heating + cooling	≤ 400kW
7) Comfort, heating + cooling	> 400kW
8) Heating	heating-only unit ≤ 400kW
9) Heating	heating-only unit > 400kW
	SCOP/ηsh
	see point 1 or 2
	SCOP/ηsh
	none



Operating conditions other than those indicated are not allowed because they may be in conflict with the issued Ecodesign conformity.

As regards the pre-sale stage, the Manufacturer reserves the right to consider and, if necessary, implement devices for specific operating conditions.



The customer (or the installer or the system operator) is responsible for the adopted operating condition and its consistency with the Ecodesign conformity issued by the Manufacturer.



The Manufacturer refuses all liability arising from improper use of the machine and more specifically from operation in temperature conditions not allowed by the technical documentation.

See also the "Intended use" and "Unintended use" paragraphs of the "Product description" chapter.

5 PRODUCT DESCRIPTION

5.1 Intended use

These units are intended for cooling (unit in cooling only version) or for cooling/heating (heat pump version) of heat-carrying fluid; they are generally used in applications in the air-conditioning and refrigeration field.

Their use is recommended within the operating limits indicated in the Technical Catalogue.

Use outside the operating limits stated in the Technical Catalogue will cause the unit to stop.

5.2 Unintended use

The unit must not be used:

- in an explosive atmosphere;
- in a flammable atmosphere;
- in extremely dusty environments;
- in an environment that is not compatible with the stated IP protection rating;
- by untrained personnel;
- in a way that does not comply with the regulations in force;
- with incorrect installation;
- with power supply defects;
- with total or partial failure to comply with the instructions;
- with lack of maintenance and/or use of non-original spare parts;
- with inefficient safety components.
- with modifications or other work not authorised by the Manufacturer.

5.3 Control and safety devices

The unit is integrally managed by an electronic microprocessor control that, through the various temperature and pressure sensors installed in the unit, keeps its operation within the safety limits.

All the parameters involved with control of the unit are shown in the “Control Manual” that is an integral part of the documentation of the unit.

The manual fully describes the logic with which the checks of the unit take place during the various operating stages.

The devices are shown in the Technical Catalogue.

5.4 Principles of operation

The principle of these units is based on using the vapour compression refrigeration cycle, characterized by 4 phases (compression, condensation, throttling and evaporation).

This cycle produces heat transfer from a fluid at lower temperature to a fluid at higher temperature, which is the opposite of what happens naturally.

In our specific case, these units consist of one or more refrigerant circuits that cool the water of a hydraulic circuit inside a heat exchanger (“evaporator”) and reject the heat through air heat exchangers (“condensers”). This happens in units intended for operation in cooling mode.

In units in heat pump operation, where hot water is produced, there is cycle reversal that reverses the function of the two heat exchangers so that the water heat exchanger becomes the condenser and the air heat exchanger becomes the evaporator.

5.5 Structure

The structure is made of galvanized sheet-iron coated with polyester powder at 180°C, which makes it highly resistant to weather conditions. All screws and bolts are stainless steel.

The structure is a load-bearing frame, with removable panelling lined with sound absorbing expanded.

5.6 Specifications

Air-condensed water chiller unit with hermetic scroll compressors, axial fans and dry-expansion plate evaporators.

5.7 Control panels

This line of units can be managed with two electronic microprocessor controls; one parametric and the other programmable. The next sections describe the basic operations for both controls, such as starting and stopping the unit, changing operation from cooling to heating and vice versa (in units with heat pump), and changing the set point.

For the other operations, refer to the manual of the control that is an integral part of the documentation of the unit.

5.7.1 Parametric control

The reference for the following instructions is the main screen that is accessed, from any other screen, with repeated pressing of the "menu" button or with pressing of the "set" button from the set point screens.



5.7.1.1 Switching the unit on/off

When the digital input of the external OK signal is open, "OFF" appears on the display and a LED flashes between the two "offs" of the word "OFF".



Fig. 8 Parametric control display with external OK signal device open

When the digital input of the external OK signal closes, if the unit was not previously switched on from the keypad, "Stby" appears on the display, otherwise the unit starts in the operating mode that was active before the digital input opened.

When "Stby" is show on the display, to switch on the unit in cooling mode, you must press button  or, in units that also work in heating mode, press button .

To switch off the unit from the keypad, press the button corresponding to the symbol present on the display.





In units where the change of cooling/heating operation is made from the keypad, if the button with the symbol that is not present on the display is pressed accidentally, the control reverses the operation of the unit.

5.7.1.2 Changing from cooling to heating

It is possible to change operation from cooling to heating and vice versa only in units that have this feature. The change can be made using the display keypad or from digital input.

In both cases, the change of operation can be made even if the unit is running. If the change of operation takes place with the unit running, the control manages this by stopping the compressors and observing the set delays before restarting them.

In units where the change of operation is from the keypad, the required operation is activated using the same buttons  or  used for switching on and switching off as described above.

In units where the change of operation is from digital input, when the input is closed, the unit can be started in heating mode only, or when it is open, the unit can be started in cooling mode only.

When the change of operation is from digital input, buttons  and  can in any case be used to put the unit in standby in the relevant operating mode.

5.7.1.3 Display of the set point

When you press and release button  the icons identifying the circuits go out and the working set point is displayed.

With the unit "OFF" or in standby mode, with the first press of button  the lower display will show "SetC" that corresponds to the cooling mode set point while its upper part will show the relevant value.

For units in heat pump mode, with the second press of the button, the lower display will show "SetH" that corresponds to the heating mode set point and its upper part will show the relevant value.

If compensation is envisaged, with the second press of the button for units in cooling only mode or with the third press for units in heat pump mode, the lower display will show "Setr" that corresponds to the real operating set point and its upper part will show the relevant value.

With the unit running, pressing on button  will cause only the set point regarding the current operating mode to appear.

5.7.1.4 Changing the set point

For units that can work in cooling mode only, the set point can be changed when they are "OFF" or in standby mode. For units that can work in both cooling and heating modes, when they are running, it is possible to change only the set point of the active function whereas when they are "OFF" or in stand by mode, both set points can be changed.

Press, for at least 3 seconds, button .

To change the value, use buttons  and .

The new value will be stored when you press button  or with automatic exiting from the page of the function by the control.

5.7.2 Programmable control

For some configurations and functionalities, a programmable control is used

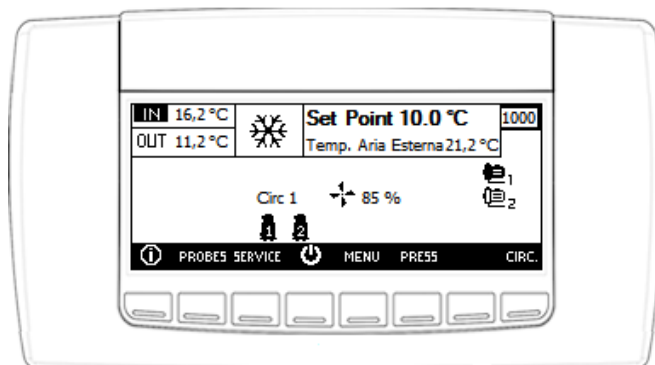

Fig. 9 Programmable control display

The reference for the following instructions is the main screen that is accessed, from any other screen, by pressing repeatedly on the button **ESC**.

5.7.2.1 Switching the unit on/off

In order to switch the unit on and off from the keypad, make sure the feature is active.

Press, for more than 2 seconds, the button with **⏻**.

5.7.2.2 Changing from cooling to heating

In order to change the operating mode from the keypad, make sure the feature is active.

The change of operating mode takes place with the unit switched off.

If the operation takes place with the unit running, the unit will switch off automatically when the change is made.

Switch off the unit by pressing, for more than 2 seconds, the button **⏻**.

With the unit switched off, press button **MENU**, and then confirm with **ENTER** and finally, press, for more than 2 seconds, the button **☀** that will become **☀** for operation in heating mode.

Press the button again **⏻** on the main screen to restart the unit.

5.7.2.3 Changing from heating to cooling

In order to change the operating mode from the keypad, make sure the feature is active.

Repeat the sequence of the previous point, and on pressing the button for more than 2 seconds

☀ the symbol will become **☀** for operation in cooling mode.

5.7.2.4 Change of set point in cooling operating mode

Press the button **MENU**, press twice on button **ENTER**. It is now possible to change the set point value, within the set limits, with buttons **▲** and **▼**.

The value must be confirmed by pressing the button **ENTER**. Pressing twice on the button **ESC** returns to the main screen.

5.8 Wiring diagram

The wiring diagram is an essential part of the documentation and is present inside each unit.

It is essential to refer to this document if you are unsure about anything or need further explanations regarding the auxiliary electrical connections and power connections as well as for the electrical specifications.

In particular, refer to the wiring diagram as regards the possibility of remotely managing the functionalities that contemplate this.

6 INSTALLATION

During installation or whenever work must be carried out on the unit, it is essential to strictly follow the instructions in this manual, comply with the directions on the unit and in any case take all necessary precautions.



The pressures in the refrigerant circuit and the electrical components can create risky situations during installation and maintenance work.

6.1 Dimensions and weight

In order to correctly position the unit, please refer to the dimensional drawing supplied with the order confirmation for its size and weight.

6.2 Installation site

The following should be taken into account to establish the best place to install the unit and the relevant connections:

- size and origin of the hydraulic piping;
- location of the power supply;
- accessibility for maintenance or repair operations;
- load-bearing capacity of the support surface;
- ventilation of the air-cooled condenser;
- orientation and exposure to solar radiation. Keep the condensing coil out of direct sunlight as far as possible;
- direction of prevailing winds. Do not position the unit in a such way that prevailing winds can cause air recirculation at the condensing coil;
- type of surface. Do not position the unit on dark coloured surfaces (e.g. tarred surfaces) so as to avoid overtemperatures during use;
- possible reflections, resonances and acoustic interactions with elements outside the unit.

All the models in the range are designed and built for outdoor installation (terraces, gardens). They must therefore not be installed under canopies or near plants (even if these would cover only part of the unit), in order to avoid the possibility of air recirculation.



It is obligatory to observe the clearances specified in the dimensional diagram of the unit.



If the unit is installed in particularly windy areas, windbreaks must be installed to prevent malfunctioning of the unit.



During the defrost cycle, units in heat pump operation allow water to flow out that freezes with sub-zero temperatures. Although the unit is installed perfectly horizontal, make slopes in the support surface to direct the defrost water into drains, wells or in any case to places where there is no danger of accident.

6.3 Installation

The units are sent from the factory already tested and they need only the electrical and hydraulic connections for installation, except the "LE" (motocondensing) versions and the "LE/HP" (reversible motocondensing) versions for which the refrigerant connections with the remote exchanger must also be made.

6.3.1 External positioning

A solid base on which to position the unit must be created.

This base must be perfectly flat and horizontal. Its dimensions must be adequate for those of the unit.

The slab must be:

- made in a suitable foundation about 15-20 cm higher than the surrounding ground;
- flat, horizontal and able to bear at least 4 times the operating weight of the unit;
- at least 30 cm longer and wider than the unit.

Although the units transmit low levels of vibration to the ground, it is advisable to lay a strip of hard rubber between the base frame and the support surface.

If better isolation is required, it is advisable to use the anti-vibration mounts available as accessory.

In the event of installation on roofs or intermediate floors, the unit and pipes must be isolated from the walls and ceilings. The units should not be positioned near private offices, bedrooms or areas where low sound emissions are required.

It is also advisable not to install the units in narrow passages or small spaces, in order to avoid reverberations, reflections, resonances and acoustic interactions with elements outside the unit.

Units equipped with standard coils (copper-aluminium) should not be installed in an environment where there is an aggressive chemical atmosphere, in order to avoid the risk of corrosion.

Particular attention should be given to atmospheres containing sodium chloride, which worsen corrosion due to galvanic currents; a unit with untreated coils must absolutely not be installed in a marine environment.

For installations in marine environments, in the vicinity of animal farms or in heavily polluting industrial areas, it is necessary to order coils with anticorrosive surface treatments.

In any case, please contact our sales department to define the most suitable solution.

6.3.1.1 Rubber anti-vibration mounts

In order to reduce vibrations transmitted to the structure, it is advisable to install the unit on rubber or spring anti-vibration mounts, supplied as an accessory and to be requested when placing the order.

The dimensional diagram with footprint shows the position and load of each anti-vibration mount.

The anti-vibration mounts must be fixed on before positioning the unit on the ground.

To install the anti-vibration mounts, see the instructions attached to the accessory.



When fixing the anti-vibration mounts, the unit should be lifted off the ground by no more than 200 mm and no parts of the body should be placed under the unit.

6.3.1.1 Rubber anti-vibration mounts

The anti-vibration mount consists of an upper metal bell in which there is a screw for fixing it to the base of the unit. The anti-vibration mount is fixed to the base through the two holes on the flange. The flange of the anti-vibration mount bears a number (45,60,70 ShA) that identifies the hardness of the rubber support.

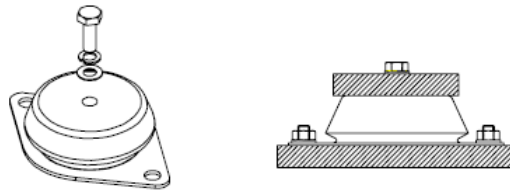

Fig. 10 Rubber/metal anti-vibration mounts

6.3.1.2 Spring anti-vibration mounts

The cylindrical spring anti-vibration mounts are suitable for isolating any source of mechanical vibration. Each anti-vibration mount bears a code that identifies the maximum load allowed.

It is very important to strictly comply with the assembly recommendations and instructions when installing the anti-vibration mounts.

Standard spring anti-vibration mounts: the frame of the unit is mounted on the anti-vibration mount with the through-screw and 2 washers.

Spring anti-vibration mounts for heavy loads: the load of the unit is borne by the entire surface of the anti-vibration mount and not just by the screw.

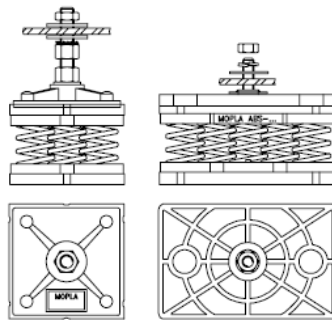

Fig. 11 Spring anti-vibration mounts

6.3.2 Noise attenuation

The units are designed and built paying particular attention to keeping down noise emission during operation.

In addition to the standard versions, there are “LN” (Low Noise) and “SLN” (Super Low Noise) versions for which further devices are used for lower noise emission.

Correct installation for both the place and the components, as shown in the relevant chapter, prevents resonances, reflections and vibrations that can be particularly bothersome.

If, after following the instructions above, further attenuation is required, the use of acoustic barriers is a valid solution.

It is essential to be careful that any work done to soundproof the unit does not affect its correct installation or its correct operation.

That is why it is necessary to avoid restricting the service spaces and installing covers that create recirculation between air supply and exhaust.

6.3.3 Minimum distances

The service spaces to comply with are shown on the dimensional drawings attached to the documentation of the unit.

It is essential to ensure an adequate volume of air on the suction side and on the delivery side of the condensing coil.

It is very important to avoid recirculation between suction and delivery, as this would lower the performance of the unit or even stop its normal operation.

The presence of very high walls near the unit will impair its correct operation.

Units should be installed a minimum of three metres apart.

It is, in any case, advisable to leave sufficient space between the units to allow removal, if necessary, of their larger components such as the exchangers, compressors or pumps.

6.4 Hydraulic connections

When preparing to connect the hydraulic circuit for the evaporator (refer to the diagrams included in the manual), it is good practice to comply with the following instructions and in any case to follow national or local regulations.

Fit the pipes to the unit using flexible couplings in order to prevent transmission of vibrations and compensate thermal expansion. (Proceed on the pumps unit in the same way).

Install the following components on the pipes:

- Temperature and pressure indicators for normal maintenance and control of the unit.
- Wells on the inlet and outlet pipes for temperature measurements, if temperature indicators are not present.
- Shut-off valves (ball gate valves) to isolate the unit from the hydraulic circuit.
- metal mesh filter with a mesh size no larger than 1 mm, situated on the exchanger inlet pipe, to protect the exchanger from slag or impurities in the pipes.
- Air valves, to be placed in the highest parts of the hydraulic circuit, to allow the non-condensable gases to be bled off.
- Expansion vessel and automatic charging valve for maintaining system pressure and to compensate thermal expansion.
- Drain valves, so that the system can be emptied for maintenance operations or seasonal stops.



It is mandatory to comply with the above requirements to facilitate the hydraulic connection operations and the maintenance operations.



The installation of a safety valve on the hydraulic circuit is strongly recommended. In the event of serious anomalies in the system or exceptional events (e.g. a fire breaks out), this will allow the system to be drained to prevent possible bursting.



If supplied with the unit, it is mandatory to install the flow switch at the chilled water outlet connection. If the flow switch is not installed, the warranty is voided immediately.



It is mandatory to fit the metal mesh filter on the water inlet pipe. If the metal filter is not fitted, the warranty is voided immediately.

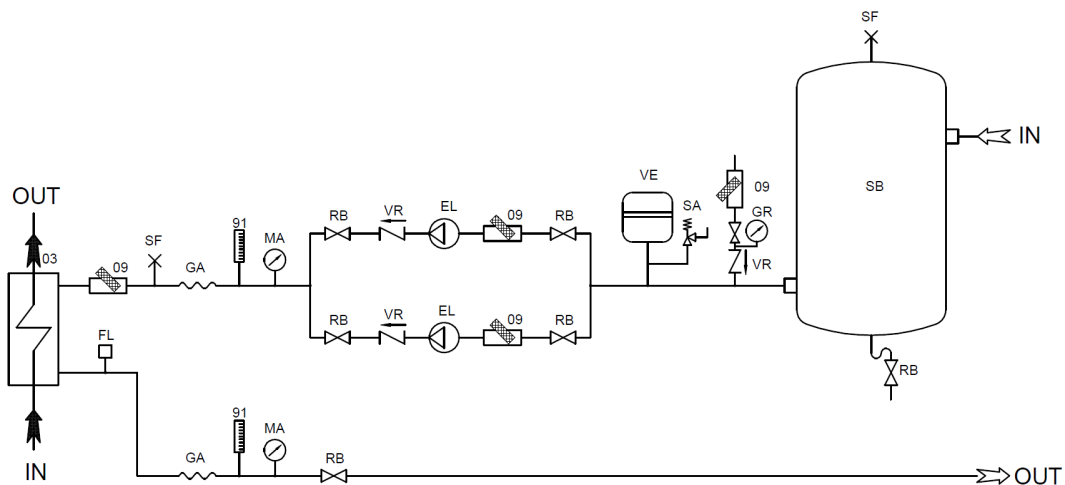

Fig. 12 Recommended hydraulic circuit

03	Evaporator
09	Water filter
91	Thermometer
EL	Motor-driven pump
FL	Flow switch
GA	Flexible coupling
GR	System filling unit
MA	Water pressure gauge
RB	Valve
SA	Safety valve
SB	Storage tank
SF	Air valve
VE	Expansion vessel
VR	Check valve



It is essential for the water to come in at the connection indicated in the dimensional diagram and with the relevant label on the unit.

If it does not, there would be a risk of the evaporator being frozen since the antifreeze probe control would be thwarted. The hydraulic circuit must be made in such a way as to ensure a constant flow of water to the exchanger in all operating conditions.

If this is not done, there will be a risk of refrigerant returning to the liquid state at the compressor inlet, with the danger of it breaking.

Operation with a variable water flow rate at the user-side exchanger is allowed only if the inverter pump is integrated in the unit (and therefore supplied by the manufacturer) and if the hydraulic circuit is made in accordance with the manufacturer's specific instructions.

6.5 System components

6.5.1 Installation of pressure sensors

If the operating logic requires the installation of pressure sensors in the system, the Manufacturer supplies a kit of measuring devices to be assembled by the fitter.

The kit consists of:

- 2 pressure sensors;
- two M-F taps (thread G $\frac{1}{4}$ ");
- 2 connectors complete with cable.

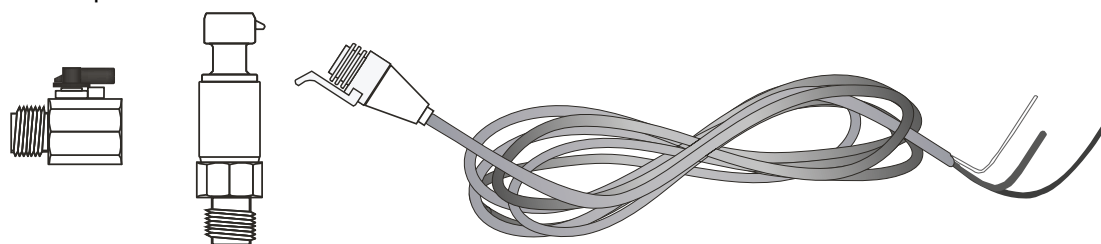

Fig. 13 Components of the kit



The kit is supplied pre-assembled inside the electrical control panel and electrically connected to the terminal board.

Components must be fitted on the system as illustrated in the hydraulic diagram of the corresponding operating logic.

Two G $\frac{1}{4}$ " sleeves (out of supply scope) are required for pressure sensor installation.

Install the sleeves vertically and in a position where the assemblies are not exposed to accidental damage.

Use a suitable sealant to ensure water tightness between the components.

After completing the thermal insulation of the hydraulic circuit, insert the connectors in the sensors and secure the cables properly.

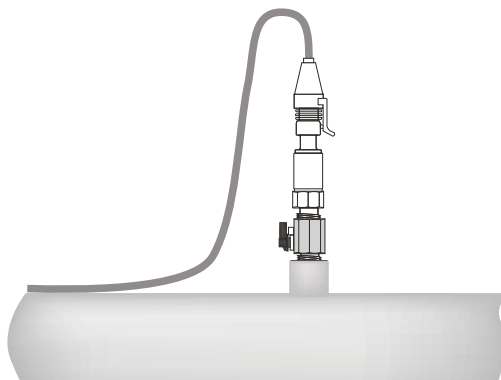

Fig. 14 Connection of a pressure sensor

It may be necessary to extend the cables.

If the cables are extended, this must be done professionally to ensure a good electrical connection and protection from moisture over time.



After the sensors have been installed, make sure they are protected from accidental damage and that the connection cables are secured properly.

6.5.2 Installation of temperature sensor

If the operating logic requires the installation of a temperature sensor in the system, the Manufacturer supplies the necessary kit to be assembled by the fitter.

The kit consists of:

- 1 threaded probe pocket G1/2";
- 1 temperature sensor.



Fig. 15 Components of the kit



The kit is supplied pre-assembled inside the electrical control panel and electrically connected to the terminal board.

Components must be fitted on the system as illustrated in the hydraulic diagram of the corresponding operating logic. A G1/2" sleeve (out of supply scope) is required for temperature sensor installation.

Install the sleeve so that the pocket and the probe are in vertical position and not exposed to accidental damage. The length of the sleeve to be used depends on the pipe diameter.

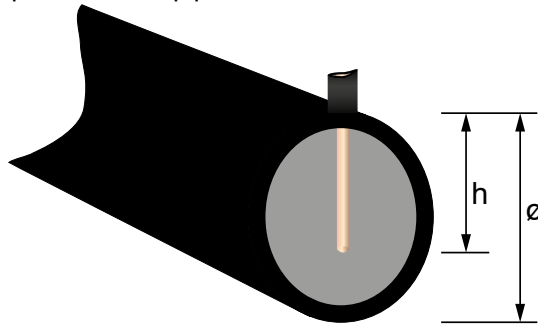

Fig. 16 Installation of pockets

Fit the pocket in position and check that distance "h" ranges between 1/4 and 3/4 the pipe diameter "Ø".

Secure the pocket to the sleeve using a special sealant to create leak tight conditions.

To ensure proper reading, coat the entire length with heat conducting paste before fitting the sensor.

Heat conducting paste ensures optimised temperature probe reading.

Connect the sensor to the terminal board, as shown in the wiring diagram of the unit.

It may be necessary to extend the cables.

If the cables are extended, this must be done professionally to ensure a good electrical connection and protection from moisture over time.



We recommend that the sleeve in which the pocket is fitted is fully isolated.



After the sensor has been installed, make sure it is protected against accidental damage and the connection cable is secured properly.

After completing the thermal insulation of the hydraulic circuit, secure the cable properly.

6.6 Electrical connections

All electrical operations must be carried out by personnel having the necessary legal requirements, and trained and informed on the risks connected with these operations.

The sizing and characteristics of the power lines and relevant components must be determined by staff qualified to design electrical systems, following the international and national regulations of the place of installation of the units in conformity with the regulations in force at the time of installation.

To install components outside the unit, you must refer to the wiring diagram supplied with the unit.

The wiring diagram, along with the manuals, must be kept carefully and made available for future work on the unit.

Overview:

- The electrical connections must comply with the information shown in the wiring diagram attached to the unit and the regulations in force in the place of installation.
- grounding is required by law;
- The installer must connect the earth cable to the PE terminal on the earth bar situated in the electrical control panel.
- Make sure the power supply voltage corresponds to the rated data of the unit (voltage, number of phases, frequency) stated on the plate on the unit.
- the standard power supply voltage (see specific wiring diagram) must not fluctuate by more than $\pm 10\%$ and the unbalance between phases must always be less than 2%. If this does not occur, contact our technical department to choose suitable protection devices.
- Make sure the power line is correctly connected with a clockwise phase sequence.
- The control circuit power supply is taken from the power line via a transformer situated in the electrical control panel; the control circuit is protected by fuses.



To fix the power cable, use power cable fixing systems that resist tensile and torsional stresses. The weight of the cables must not be borne by the electrical connection system.



Make sure no voltage is present before carrying out any operation on electrical parts.



The cross-section of the cable and the line protection devices must correspond to those indicated in the wiring diagram.



The connections to the electrical control panel must be made maintaining the stated IP protection rating.



If you use a residual current device to protect the power line, in units with inverter, use type "B" or "B+" residual current devices, with minimum tripping threshold of 300 mA and delayed tripping.



If the circulation pumps are not installed on the unit, potential free contacts are available as accessory for controlling the external pumps.
If the potential free contacts for controlling the circulation pumps are present, connect the pumps as shown in the wiring diagram.



The electrical connections to potential-free contacts, which are powered by external sources, must be suitably protected against overcurrent and earth faults.

The circuit of the potential-free contacts inside the electrical control panel is made using orange cable.

6.7 Refrigeration connections

For the "LE" (motocondensing) versions and the "LE/HP" (reversible motocondensing) versions, the refrigerant connections must be made between the unit and the remote exchanger.

The "LE" and "LE/HP" version units are "dry run" tested, and the refrigerant circuit is charged at the factory with a mixture of nitrogen and helium at a pressure of about 10 bar.



Check that the unit is pressurised as this will confirm that the refrigerant circuit has not been damaged in transit.



The following operations require pressurised pipes and brazed connections to be made, and these must be carried out by skilled staff with the necessary qualifications in accordance with current regulations.

6.7.1 Piping implementation

In order to lay the pipes, use copper pipes, of a size suitable for the cooling capacity and the distance to be covered and of an adequate thickness for the maximum design pressure and the type of refrigerant used.

The route of the pipes must be as short and straight as possible, making sure the following basic rules are complied with:

- use the fewest number of bends possible, preferably as wide as possible;
- make a slight slope in the suction line (1%) in the horizontal sections so that the oil is carried more easily in the installations of cold only units "LE". For the installation of reversible units "LE/HP", the horizontal sections of the suction/delivery line must not slope at all;
- fit suitable syphons every 4 metres, in the vertical riser sections of the suction pipe (suction/delivery for reversible units "LE/HP");
- support the horizontal and vertical lines with suitable vibration dampers;
- insulate the suction line (suction/delivery for reversible units "LE/HP") with insulating material that is at least 9 mm thick;
- solder the joints, avoiding butt welds by using sleeves or enlarging the tubes;
- adequately protect the various components such as valves or taps fitted nearby, e.g. by wrapping them with wet rags, during braze-welding;
- once the junctions have been completed, blow-clean the tubes to remove any dirt;
- press the plant to search for any leaks.

The maximum height difference between the unit and the remote exchanger is 15 equivalent metres for any type of installation.

The recommended diameters for equivalent lengths up to 30 m are given below.

Recommended diameters for R410A - The thickness of the pipe must be compatible with the refrigerant used and with current regulations.

Model	Equivalent length 10 m		Equivalent length 20 m		Equivalent length 30 m	
	Gas	Liquid	Gas	Liquid	Gas	Liquid
3.2	28	18	28	18	28	18
4.2	28	18	28	18	28	18
5.2	28	18	28	18	28	18
6.2	35	22	35	22	35	22
7.2	35	22	35	22	35	22
8.2	35	28	35	28	42	28
9.2	42	28	42	28	42	28
10.2	42	28	42	28	42	28
12.2	42	28	42	28	42	28
13.2	42	28	54	28	54	28
15.2	54	35	54	35	54	35
16.2	54	35	54	35	54	35
14.4	35	22	35	22	35	22
16.4	35	28	35	28	42	28
18.4	42	28	42	28	42	28
20.4	42	28	42	28	42	28
24.4	42	28	42	28	42	28



The above mentioned diameters were chosen in order to optimise the performance of the units, contemporaneously ensuring the proper operation at the permissible conditions and to contain the refrigerant charge within reasonable limits.

6.7.2 LE version: unit installed at a higher level than the remote exchanger

A summary is given below of the measures to be taken if the unit is installed at a higher level than the evaporator.

There must be syphons on the vertical sections of the suction line "G" to facilitate oil return to the compressor. The height "h" must be less than 4 metres.

In the horizontal sections of the suction line "G", make a slope of at least 1% to facilitate oil return to the compressor.

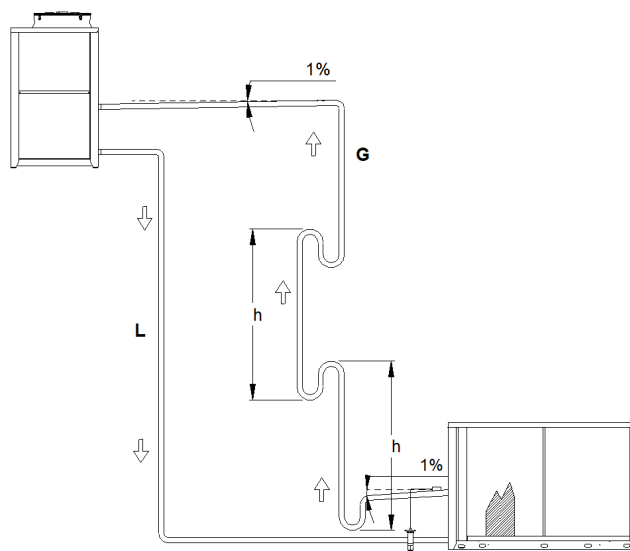

6.7.3 LE version: unit installed at a lower level than the remote exchanger

Fit a syphon on the highest suction line "G" of the evaporator in order to prevent liquid refrigerant from going towards the compressor when the unit is not running.

In the horizontal sections of the suction line "G", it is advisable to have a slope of at least 1% to facilitate oil return to the compressor.

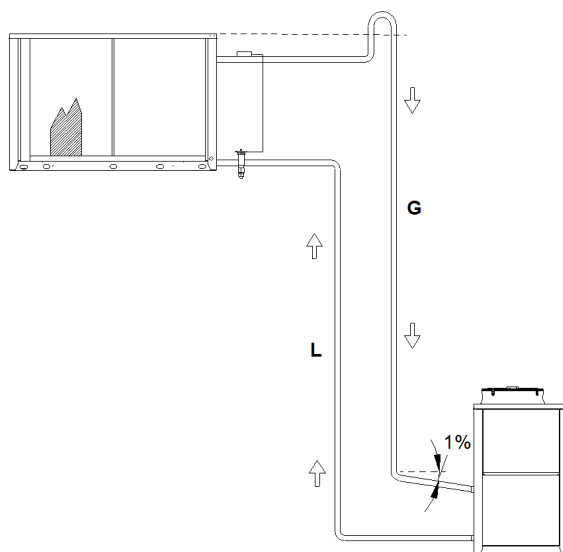

6.7.4 LE/HP version: unit installed at a higher level than the remote exchanger

There must be syphons on the vertical sections of the suction/delivery line "G" to facilitate oil return to the compressor. The height "h" must be less than 4 metres.

The horizontal sections of the suction/delivery line "G" must not slope at all.

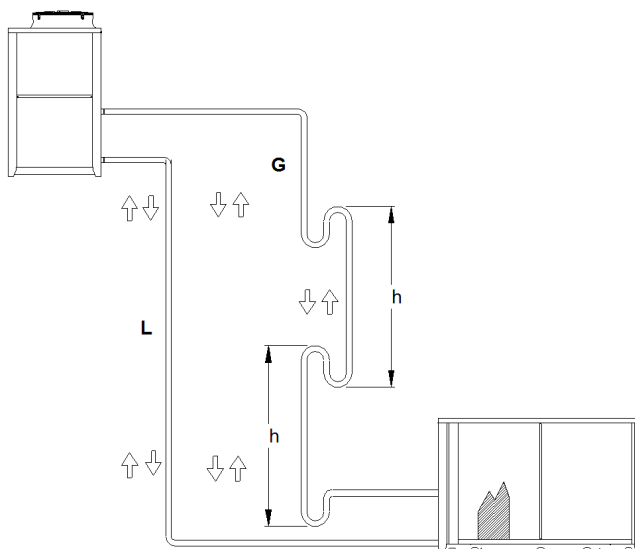

6.7.5 LE/HP version: unit installed at a lower level than the remote exchanger

Fit a syphon on the highest suction/delivery line "G" of the evaporator in order to prevent liquid refrigerant from going towards the compressor when the unit is not running.

There must be syphons on the vertical sections of the suction/delivery line "G" to facilitate oil return to the compressor. The height "h" must be less than 4 metres.

The horizontal sections of the suction/delivery line "G" must not slope at all.

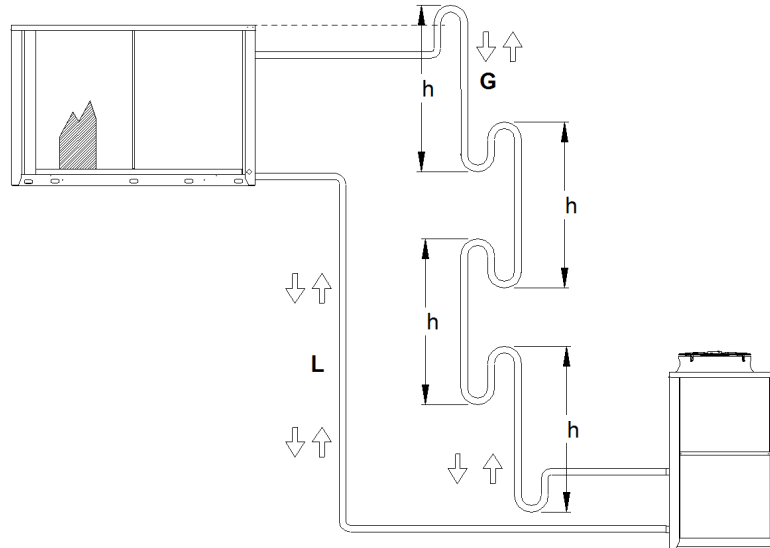

6.8 Expansion valve

The "LE" and "LE/HP" units can have an expansion valve for each refrigerant circuit as accessory, to be installed by the installer, on the remote exchanger.

The supplied expansion valve is sized with reference to the envisaged operating conditions for the unit.

Carry out the installation following the documentation attached to the valve.

6.9 Vacuum and refrigerant charge

Open the taps of the unit and evacuate the pre-charge of nitrogen and helium before completing the refrigerant connections. Do not leave the refrigerant circuit open for more than 15-30 min as the high hygroscopic nature of the oil can cause it to absorb moisture that would be detrimental to the circuit.

Carry out the vacuum of the entire system with a high vacuum pump, able to reach 0.1 mbar of residual pressure. Connect the vacuum pump to several points of the refrigerant circuit in order to ensure better evacuation.



Never use the compressor as a vacuum pump, doing so will invalidate the warranty.



On units fitted with inspectable filter, immediately before starting to make the vacuum, insert the filtering cartridge in the filter body present in the liquid line. This cartridge is supplied with the unit and located in the electrical control panel.

Once the vacuum has been obtained, charge the system through the charging port 5/16" SAE placed on the liquid line. Perform charging in liquid form. The tables below show the estimated refrigerant charges for the units and for the connecting pipes to which will be added the charge contained in the remote exchanger.

As an indication, the charge regarding the remote exchanger can be considered a multiplication of its volume by 0.15.

The final charge may differ slightly depending on the necessary adjustments (see next chapters).

Refrigerant charges* for units without remote exchanger, excluding pipes

Model	Coil type	
	MCHX - [kg]	Cu/Al - [kg]
3.2	3,6	11
4.2	3,7	11,2
5.2	3,8	11,9
6.2	4,9	16,9
7.2	5	16,9
8.2	8,2	22,8
9.2	8,4	25,5
10.2	8,4	25,5
12.2	8,6	25,5
13.2	8,6	25,5
15.2	14,4	38,3
16.2	14,4	38,3
14.4	13,2	39,8
16.4	13,2	41,6
18.4	21,2	52,2
20.4	21,2	52,2
24.4	21,6	52,8

* The table shows the charges for units with microchannel coil (MCHX) for cooling only operation (LE) with evaporation at 7.5°C and air at 35°C or copper/aluminium (Cu/Al) for reversible operation (LE/HP), under the same conditions as regards operation in cooling mode and with condensation at 40°C and air at 7°C for operation in heat pump mode.

Additional refrigerant charges R410A per linear metre of pipe

Diameter (mm)	Gas (kg/m)	Liquid (kg/m)
16	0,014	0,139
18	0,019	0,182
22	0,029	0,285
28	0,045	0,445
35	0,074	0,729
42	0,111	1,082
54	0,182	1,779
67	0,289	2,825

6.10 Topping up with oil

According to the length and diameter of the pipes made for remote exchanger connection, it may be necessary to increase the oil charge. The oil level must be checked under nominal working conditions and with the unit at the lowest available capacity for at least two hours, using the sight glass on the oil manifold.

So that the oil charge is sufficient, the level under these operating conditions must reach at least $\frac{1}{4}$ of the sight glass; if it does not, more oil must be added.

The amount of additional oil needed can at most be 10% of the total oil charge present in the refrigerant circuit of the unit.

The amount of oil put in the refrigerant circuit at the factory is shown in Technical Catalogue for the unit. Alternatively, it is possible to work this out by adding together the amount of oil in each compressor shown on the respective data plate. This data plate also shows the type of oil.



Top up with the same type of oil or with perfectly equivalent oil.



If after topping up, with operation at minimum capacity, the oil has not reached the minimum level, check that there are no oil traps along the remote pipes, that syphons are present in the riser sections and that pipes of the correct diameter are used.

These operations must be carried out only by skilled staff with the necessary qualifications in accordance with current regulations. If required, the manufacturer will be pleased to offer suggestions but in any case these will not change the installer's exclusive responsibility for installing the system and carrying out the operations described above.

7 COMMISSIONING

7.1 Preliminary operations

Make sure the main disconnect switch is in the OFF position.



In units with pumps, their power supply is mechanically locked.
Restore functional conditions only on starting.



If the pumps of the unit are not locked, electrically isolate them by operating the protective devices, to prevent automatic starting, in the event of antifreeze function activation, during the preliminary operations.
Restore functional conditions only on starting.



To avoid damage to the mechanical seals, do not start the circulation pump before completely filling the system with water.



If a pump has to be replaced, after replacing it, make sure the valves are open and the pump is full of water before enabling its operation.

Before filling the hydraulic system, check that the drain valve is closed and that all the air valves are open.

Open the shut-off devices of the system and start to fill it by slowly opening the water filling valve.

When water begins to come out through the air valves, close them and continue filling until the pressure value envisaged for the system is reached.



The unit should only be started up by qualified personnel authorised by the manufacturer.



All the units are pre-charged with refrigerant gas, so the refrigerant circuit is pressurised.

Check:

- that the electrical connection has been made correctly and that all terminals are properly tightened;
- that the voltage on the RST terminals is $400\text{ V} \pm 10\%$ (or the rated voltage of the unit if there are special voltages). If the voltage fluctuates frequently, contact our technical department to choose suitable protective devices;
- that the gas pressure in the refrigerant circuits is shown on the pressure gauges (if present) or on the control display;
- that there are no refrigerant fluid leaks, using a leak detector, if necessary (the presence of oil stains may be a sign of refrigerant leaks);



Be careful with the electrical checks and use only suitable tools.

Position the master switch of the unit to ON and check on the display of the control that the unit is OFF in order to prevent it from starting.

Check that the heaters in the compressor crankcase are powered correctly.



The heaters in the compressor crankcase are switched on when the master disconnect switch is closed: this must be done at least 12 hours before starting the unit.

To check that the heaters are working correctly, check that the lower part of the compressors is hot and in any case at a temperature of 10 - 15 °C above ambient temperature.

Check:

- that the hydraulic connections have been made properly, according to the instructions given on the inlet / output plates and that a mechanical filter has been installed at the unit's inlet (a mandatory component, whose absence will invalidate the warranty);
- that the hydraulic system has been vented, eliminating any excess air, loading it gradually and opening the venting devices on the top;
- that the pump has been bled properly;
- that the installer has organised a storage tank with the appropriate capacity for the volume of the system's water.

To bleed the pump, use the fill plug on the volute, as shown in the image.

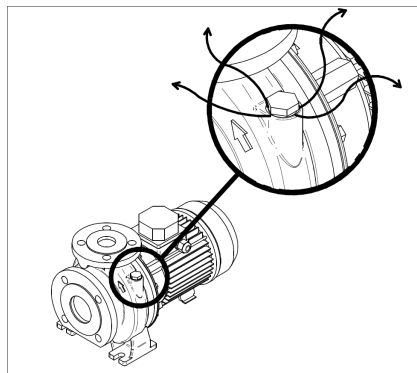

Fig. 17 Bleeding the pump



Before starting the unit, check that all the closing panels of the unit are in place and secured with fixing screws.

7.1.1 Checking the pre-charge of the expansion vessel

The values of the pre-charge pressure and the maximum pressure at which it can operate are stated on the label present on the expansion vessel.

The pre-charge pressure of the expansion vessel must be adjusted to the hydraulic pressure at the point of installation. At the time of installing the unit, make sure the pre-charge value is equal to the hydrostatic pressure value at the point of installation increased by a precautionary pressure value (at least 0.3 bar), to ensure there are no areas under vacuum in the system.

$$pVE = 0,3 + \frac{Hmax}{9.81}$$

where

- pVE: new pre-charge pressure of the expansion vessel [barg]
- Hmax: difference in level between the highest point of use and the installation level of the unit [m]

If the calibration value obtained from the calculation is lower than the pre-charge value stated on the label, keep the existing pre-charge value.

The maximum value of the pre-charge pressure corresponds to the calibration pressure of the safety valve.



The checking of the pre-charge must be done for each installed vessel

7.1.2 Checking the volume of the expansion vessel

As the pre-charge pressure increases, the maximum volume of the system supported by the expansion vessel supplied as standard, decreases.

$$VI = VVE / Ce \cdot \left[1 - \frac{1 + pVE}{1 + pVS} \right]$$

where

- VI: volume of the system supported by the expansion vessel [l]
- VVE: volume of the expansion vessel [l]
- Ce: expansion coefficient of water
- pVE: pre-charge pressure of the expansion vessel [barg]
- pVS: calibration pressure of the safety valve [barg]

If the actual volume of the system is higher than this maximum value, an additional expansion vessel of adequate volume must be installed.

After filling the hydraulic circuit, the pressure at the expansion vessel must be just a little higher than the pre-charge pressure.

If there are points of use placed at levels lower than the level at which the unit is installed, check that the point of use is able to withstand the maximum pressure that can be generated.

7.1.3 Preliminary operations for LE and LE/HP units

In addition to the previous general checks, the units with remote exchanger require further investigation:

- check the correct connection of the environment control to the terminals as in the wiring diagram;
- make sure there is an air flow control switch in the remote exchanger (in the case of units with several remote exchangers, a flow control switch must be installed for each one);
- make sure the fans are turning the right way;
- follow the instructions given in the documentation for the remote exchanger.

7.1.4 Preliminary operations for the Free Cooling No Glycol circuit

The units are dispatched from the factory with the free cooling circuit empty.

It is the installer's job to fill the free cooling circuit with an antifreeze solution.

In addition to the general checks above, in the Free Cooling No Glycol unit also check:

- that the free cooling hydraulic circuit has been filled with an antifreeze solution, with the percentage of glycol required by the operating conditions;
- that the free cooling hydraulic circuit has been bled, to remove any remaining air, by filling it gradually and opening the bleed devices on top.



Make sure the percentage of glycol is suitable for the operating conditions expected in the place of installation.

7.2 First starting

When the unit is started for the first time, some important tests and checks must be done.

7.2.1 Hydraulic tests

So that the unit can operate, the external OK signal device must be closed (refer to the wiring diagram provided with the unit).

The external OK signal input must be short-circuited if not needed for system requirements.

Water circulation can be managed by the control of the unit or by a control outside the unit.



If water circulation is controlled by an external control, the pump must be started before the unit starts and stopped after the unit stops.



We advise an advance on starting and a delay on stopping of at least 5 minutes.



Before starting the unit, make sure the system has been bled correctly.



Before starting the unit, make sure the pump has been bled to prevent damage to the hydraulic seals.



For units equipped with pump unit, check that the pumps controlled with direct starting are rotating in the correct direction.

7.2.2 Start

Start the unit by acting on the user interface of the control.

Check that the water flow switch/differential pressure switch is working correctly by closing the shut-off valve at the outlet of the unit; this should cause the alarm to be displayed on the user interface of the unit.

If not, restore correct operation.

Reopen the valve, reset the alarm and restart the unit.

For units equipped with pump unit, if the pump is noisy, close the delivery valve until normal operation has been restored. This can occur when the head loss of the system differs considerably from the discharge head of the pump.



If there is a water leak on first start-up, it could be a problem with bedding in of the mechanical seal. We therefore advise pressurizing the pump body 2 or 3 times by closing and opening the delivery valve so as to correctly bed in the seal.

If this operation does not solve the problem, contact the technical support department.

7.2.3 Functional tests

With the starting of the unit, a few seconds after the starting of the pump, if managed by the control, the compressors will start according to the request of the thermoregulation.

After a few hours of operation of the compressors, check that the liquid sight glass has a green ring: if it is yellow, there is moisture in the circuit. In this case, the circuit must be dried by qualified authorised personnel.

Check that bubbles do not appear at the liquid sight glass. The continuous passage of bubbles can indicate there is insufficient refrigerant and it needs to be topped up. In this case, check that the subcooling value is at least 5°C. But the presence of a few bubbles is allowed during transients.

The end user is required to keep a register of the unit (not supplied), which will allow a record to be kept of the work carried out on the unit. This will make it easier to appropriately organize the work to facilitate the checks and the prevention of malfunctions.

State the following in the register: the type of refrigerant, the date and type of work done (routine maintenance or repair), description of the work with any parts replaced, measures implemented, the operator who carried out the work and his qualification.

7.3 System testing

Specific logics have been developed according to which the controller manages the hydraulic systems connected to the unit.

The management logics are intended to increase system efficiency and save energy for water circulation at the same time. With the help of these logics, the circulating water fulfils the demands of the system, without exceeding the design flow rate limits and without jeopardising correct operation of the cooling unit.

Each management logic refers to a specific system type and it requires some arrangements both at the time of installation and at start-up.

7.3.1 Flowzer VP

The “VP” function requires that the pump operates at constant speed, which is made possible by the inverter fitted to control it.

The pump speed must be set up to achieve the system rated flow.

This function is useful when the flow rate of the pump aboard the unit is higher than the rated flow. The result of flow rate reduction is energy consumption saving.

The reduction of the pump speed is set as a percentage value of the nominal speed.



When the pump speed is changed manually, attention must be paid to avoid reducing the water flow rate to below the minimum value allowed for the unit.



Two pump speed setpoints are provided for free cooling units: one for cases when free cooling is disabled and one for cases when free cooling is enabled in order to make up for head losses experienced in the water coil.

For free cooling units with decoupling exchanger (FC/NG) where the head losses do not change, only one value is set.



Do not set the water flow rate outside the operating limits allowed in the Technical Catalogue.

The speed of the pump in units featuring an advanced controller is set up using the controller display. The speed of the pump in units featuring a base controller is set up using the inverter display.

7.3.1.1 Setting of pump speed (advanced controller featured)

To set the desired water flow rate as the operating set value, manually check the percentage pump speed to which it corresponds.

Then manually edit the percentage speed of the pump until the water flow rate required for operation is achieved and finally store this value as the operating set.

The necessary steps are described below:

- go to the main screen and press the arrow right button;
- click the arrow down button to select the “Flowzer” function and then press “Enter” to confirm;
- double click the “two arrows down” button and gain access to the screen where parameters are set up manually;
- press the “arrow” buttons to move and then “ENTER” to confirm your selection in order to enable manual operation and edit the pump speed percentage value until the required water flow rate is achieved;
- press the “two arrows up” button to go back to the previous screen: press the “arrow” buttons and then “ENTER” to confirm in order to set the percentage value that has been manually stored in the operating set.

The controller in units featuring a heat pump offers the possibility to set a percentage speed for operation in cooling mode and one percentage speed for operation in heating mode.

If two sets are required, the same percentage value must be set in both.

The pump operating speed percentage in free cooling units must be set up both when free cooling is enabled and when it is not.

The operator has to repeat the manual procedure to find the pump operating speed with the free cooling valve open and then closed.

For free cooling units with decoupling exchanger (FC/NG) where the head losses do not change, only one value is set.



At the end of the manual procedure to determine the flow rate under possible conditions, make sure that operation is switched back to automatic mode.

7.3.1.2 Setting of pump speed (base controller featured)

If the constant water flow rate to the system is to be adjusted through adjustment of the speed of the pump present in the unit, the inverter that controls it must be suitably adjusted.

The inverter installed in the unit is already factory preset to operate at a constant flow rate.

The frequency set at 50 Hz at the factory must be reduced until the desired flow rate is obtained.

Parameters must be entered on the inverter display to set up the desired water flow rate.

The inverter installed in the unit is already factory preset for the required type of adjustment.

It is however necessary to complete the calibration according to the specific requirements of the system by following the instructions given below.

The parameters are edited using the keypad present on the inverter.

Parameters must be entered on the inverter display to set up the desired water flow rate.

The inverter installed in the unit is already factory preset for the required type of adjustment.

It is however necessary to complete the calibration according to the specific requirements of the system by following the instructions given below.

The parameters are edited using the keypad present on the inverter.



Access and edit only the parameters shown here.

Do not edit other parameters without the Manufacturer's prior permission.

The inverter installed in the unit is already factory preset to operate at a constant flow rate.

The frequency set at 50 Hz at the factory must be reduced until the desired flow rate is obtained.



For free cooling units, set the frequency value with and without free cooling active and then with and without the head losses of the free cooling coil.

For free cooling units with decoupling exchanger (FC/NG) where the head losses do not change, only one value is set.



Do not set the water flow rate outside the operating limits allowed in the Technical Catalogue.

How to set up parameters on the inverter display in **non free cooling** units

- press "Menu", go to "Parameters" using the arrow buttons and confirm with "Select";
- in the "Parameters" menu, select "Complete List" using the arrow buttons and confirm with "Select";
- using the arrow buttons, select group "28" and confirm with "Select";
- using the arrow buttons, select parameter "28.26" and confirm with "Edit";
- using the arrow buttons, set the desired frequency value "1" and confirm with "Save";
- to exit the settings, press the "back" and "exit" button 3 times.

How to set up parameters on the inverter display in **free cooling** units - free cooling function **not enabled**

- press "Menu", go to "Parameters" using the arrow buttons and confirm with "Select";
- in the "Parameters" menu, select "Complete List" using the arrow buttons and confirm with "Select";
- using the arrow buttons, select group "28" and confirm with "Select";
- using the arrow buttons, select parameter "28.26" and confirm with "Edit";
- Use the arrow buttons to set the desired frequency value "1" and then press "Save" to confirm.



Now activate the free cooling by manually operating the 3-way valve and the free cooling relay present in the electrical control panel.

Resume the setting with the free cooling active and:

- using the arrow buttons, select parameter "28.27" and confirm with "Edit";
- using the arrow buttons, set the desired frequency value "2" and confirm with "Save";
- to exit the settings, press the "back" and "exit" button 3 times.

Resume the setting with the free cooling active and:

- using the arrow buttons, select parameter "28.27" and confirm with "Edit";
- using the arrow buttons, set the desired frequency value "2" and confirm with "Save";
- to exit the settings, press the "back" and "exit" button 3 times.

Once the settings are completed, the inverter will automatically adjust the flow rate to the set speeds with activation and deactivation of free cooling operation.

7.3.2 Flowzer DT

The “DT” function is designed to change the pump speed in order to have a constant temperature difference between the unit inlet and outlet.

The resulting effect is that the temperature of water supplied to the system is constant. When the load is reduced, the water flow rate is reduced accordingly, which results in consumption saving.

The controller keeps the flow rate through the unit within a range of safety values in order to preserve it in good operating condition.

This function is designed for application on different types of hydraulic circuit in the system that are connected to the unit.

Depending on the application, attention must be paid to the construction arrangements of the system.

7.3.2.3 System type 1

The pump in the unit is also used for circulating water in the system.

A sample diagram is shown below.

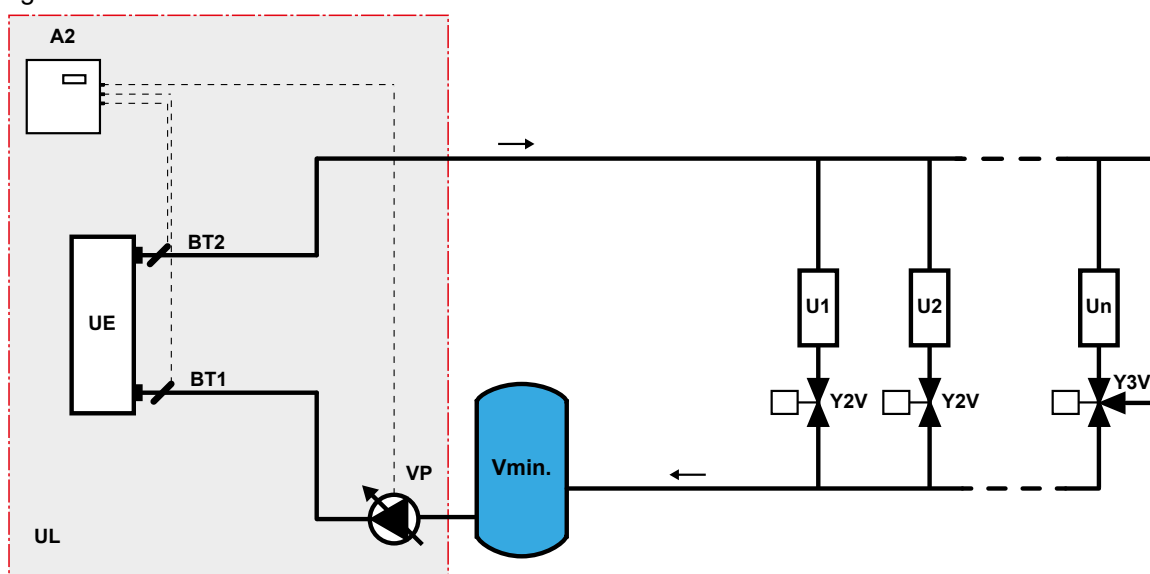

The abbreviations present in the diagram indicate:

- A2 = cooling unit controller
- BT1 = unit input temperature sensor
- BT2 = unit output temperature sensor
- EU = heat exchanger in cooling unit
- VP = variable flow pump
- U1, U2 .. Un = points of use present in the system/plant
- Y2V = 2-way valve servo controls
- Y3V = 3-way valve servo controls
- Vmin. = minimum water volume in the system/plant
- UL = limit of the supply.

This type of system requires that the min. water flow rate is also guaranteed when there is no load. This is made possible through the installation of 3-way valves on the user points.

The installation of 3-way valves on the furthest user points also provides for greater thermal flywheel, which enables limiting the capacity of the buffer tank.

7.3.2.1 Setting the operating setpoint difference

The units are shipped from the factory with a setpoint difference value of 5°C.

The procedure below explains how to edit the factory value.

- go to the main screen and press the arrow right button;
- click the arrow down button to select the "Flowzer" function and then press "Enter" to confirm;
- Press the button "SET" to access the screen where the setpoint difference value is set up: use the "arrow" buttons to move and select the parameter to be edited.
- Press "ENTER" to enable the edit window.
- Use the "arrow" buttons to set the new value and press "ENTER" to confirm.



Check that the flow rate through the heat exchanger in the unit, including without thermal load, is within the operating limits admitted in the technical catalogue.

7.3.2.2 System type 2

This system consists of a primary and a secondary circuit and it is also fitted with a hydraulic circuit breaker to make up for any difference in flow rate between the two circuits.

The controller modulates the speed of the pump in the primary circuit in order to keep constant the temperature difference between the unit inlet and outlet. Additionally, it provides for the correct water flow rate at all times by reading the pressure difference on the evaporator.

A sample diagram is shown below.

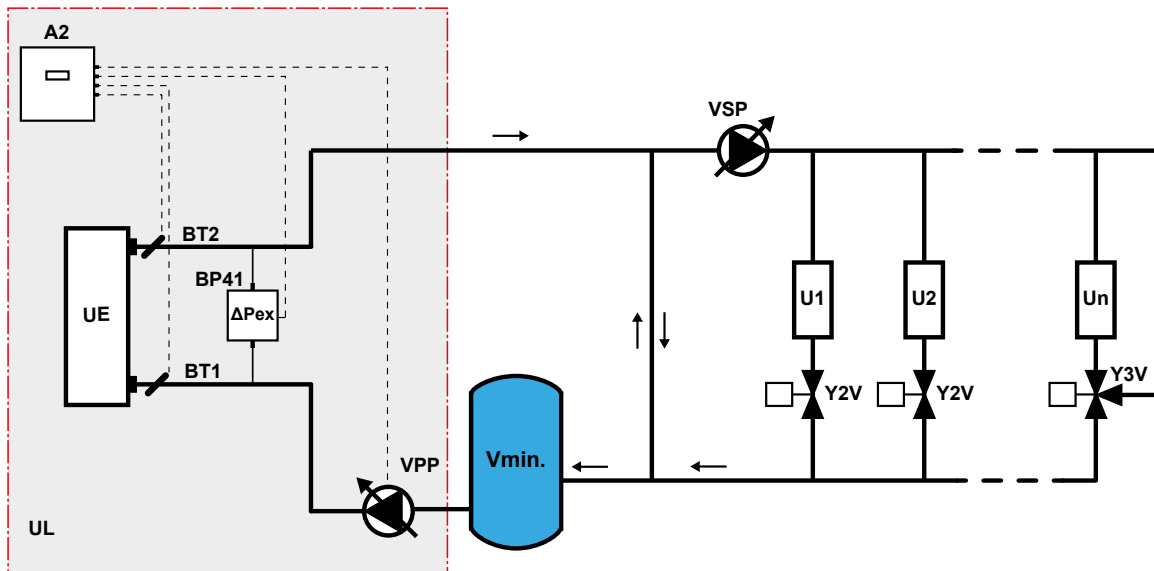

The abbreviations present in the diagram indicate:

- A2 = cooling unit controller
- BT1 = unit input temperature sensor
- BT2 = unit output temperature sensor
- EU = heat exchanger in cooling unit
- BP41= differential pressure sensor;
- ΔP_{ex} = pressure difference at the ends of the unit;
- VPP = variable flow pump in primary circuit;
- VPS = variable flow pump in secondary circuit;
- U1, U2 .. Un = points of use present in the system/plant
- Y2V = 2-way valve servo controls
- Y3V = 3-way valve servo controls

- V_{min} = minimum water volume in the system/plant
- UL = limit of the supply.

If the operating logic of the secondary circuit includes stopping of the water flow rate, the capacity of the buffer tank must be sized against the min. volume of water required for unit operation.

If user points with 3-way valves are installed in the system and water is circulated to the secondary circuit, the capacity of the buffer tank can be reduced.

To this purpose, the 3-way valves should be fitted on the furthest user points.

The bypass pipe must be of the same diameter as the connections of the unit.

7.3.2.3 Setting the operating setpoint difference

The units are shipped from the factory with a setpoint difference value of 5°C.

The procedure below explains how to edit the factory value.

- go to the main screen and press the arrow right button;
- click the arrow down button to select the “Flowzer” function and then press “Enter” to confirm;
- Press the “SET” button and access the screen where the setpoint difference value is set up.
- Press “ENTER” to enable the edit window.
- Use the “arrow” buttons to set the new value and press “ENTER” to confirm.



Check that the flow rate through the heat exchanger in the unit, including without thermal load, is within the operating limits admitted in the technical catalogue.

7.3.2.4 System type 3

The pump in the unit is also used for circulating water in the system.

A hydraulic circuit breaker controlled by a bypass valve ensures water circulation also in cases when there is no load.

As the load is reduced, the water flow rate in the system is reduced and so is the pump speed.

If the load demand is such as to excessively reduce the water flow rate in the unit, the bypass valve is opened to make up for any missing water.

The connections of the servo control in the bypass valve have to be implemented as shown in the wiring diagram.

A sample diagram is shown below.

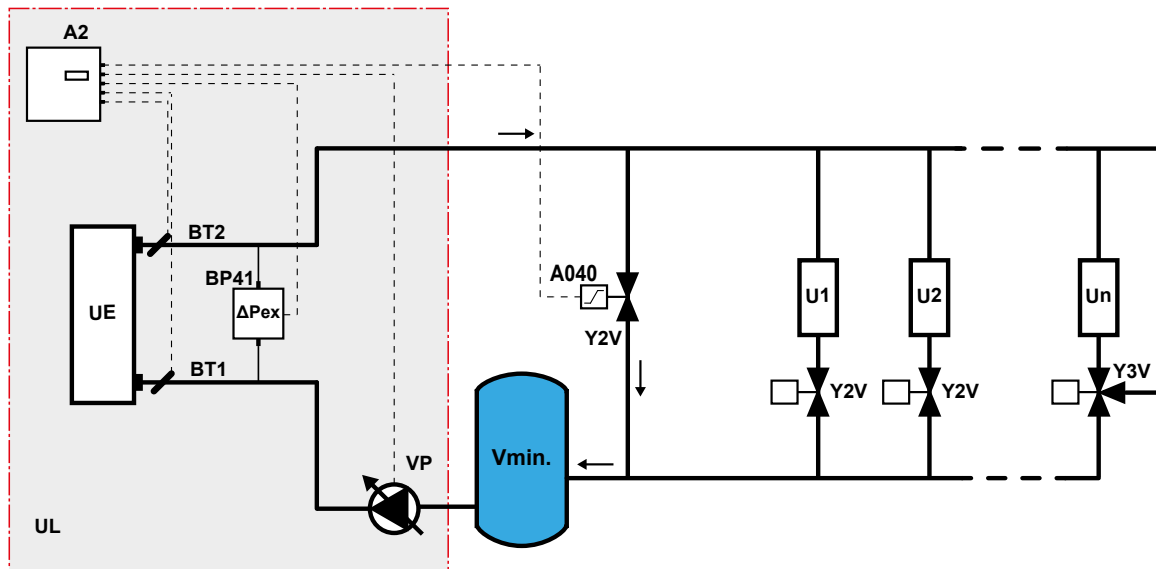

The abbreviations present in the diagram indicate:

- A2 = cooling unit controller
- BT1 = unit input temperature sensor
- BT2 = unit output temperature sensor
- EU = heat exchanger in cooling unit
- BP41= differential pressure sensor;
- ΔP_{ex} = pressure difference at the ends of the unit;
- VPP = variable flow pump in primary circuit;
- VPS = variable flow pump in secondary circuit;
- U1, U2 .. Un = points of use present in the system/plant
- Y2V = 2-way valve servo controls
- Y3V = 3-way valve servo controls
- Vmin = minimum water volume in the system/plant
- UL = limit of the supply.

User points in the system provided with 3-way valves help reduce the capacity of the buffer tank.

To this purpose, the 3-way valves should be fitted on the furthest user points.

The bypass pipe must be of the same diameter as the connections of the unit.

7.3.2.5 Setting the operating setpoint difference

The units are shipped from the factory with a setpoint difference value of 5°C.

The procedure below explains how to edit the factory value.

- go to the main screen and press the arrow right button;
- click the arrow down button to select the “Flowzer” function and then press “Enter” to confirm;
- Press the “SET” button and access the screen where the setpoint difference value is set up.
- Press “ENTER” to enable the edit window.
- Use the “arrow” buttons to set the new value and press “ENTER” to confirm.



Check that the flow rate through the heat exchanger in the unit, including without thermal load, is within the operating limits admitted in the technical catalogue.

7.3.3 Flowzer VDE

The “VDE” function is used to set the speed of the pump to such level that the pressure difference between the unit inlet and outlet is kept constant and the water flow rate is consequently kept constant.

The speed of the pump is set automatically to preserve the desired flow through the heat exchanger in the unit.

This function is useful when the head of the pump aboard the unit is greater than the system requires, which would result in a higher water flow circulating.

The result of flow rate reduction is energy consumption saving.

The value corresponding to the difference between the input and the output pressure needs to be monitored to ensure the correct water flow.

In heat pump units the controller is designed to offer the opportunity to set two pressure difference values: one for cooling and one for heating.

Please find below the hydraulic diagram of a system where the unit can be installed.

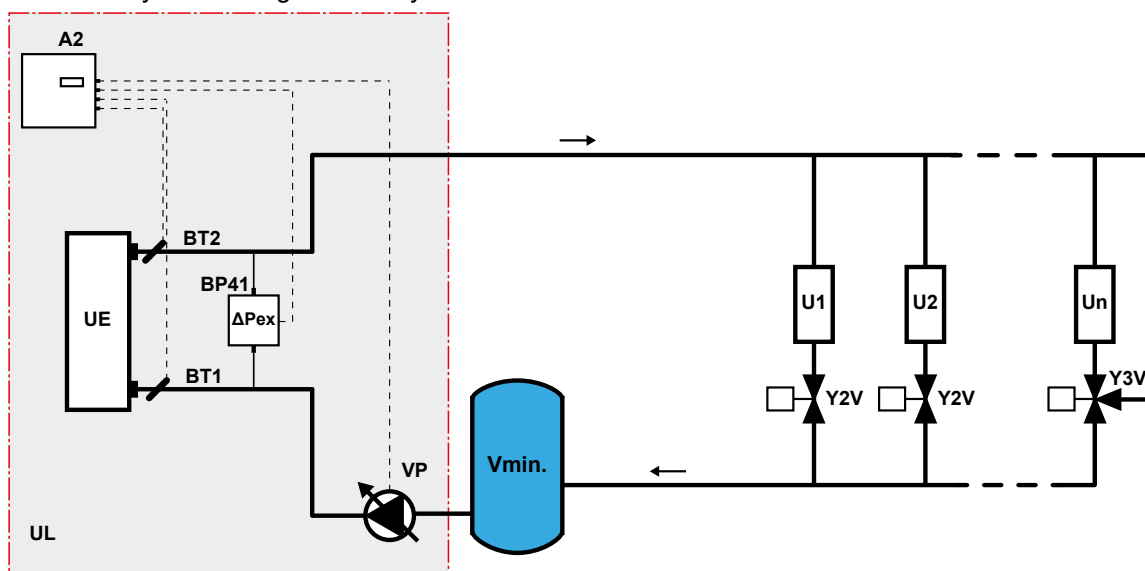

The abbreviations present in the diagram indicate:

- A2 = cooling unit controller
- BT1 = unit input temperature sensor
- BT2 = unit output temperature sensor
- EU = heat exchanger in cooling unit
- BP41= differential pressure sensor;
- ΔP_{ex} = pressure difference at the ends of the unit;
- VP = variable flow pump
- ΔP_p = pressure difference at the ends of the system
- U1, U2 .. Un = points of use present in the system/plant
- Y2V = 2-way valve servo controls
- Y3V = 3-way valve servo controls
- Vmin = minimum water volume in the system/plant
- UL = limit of the supply.

This type of system requires that the min. water flow rate is also guaranteed when there is no load. This is made possible through the installation of 3-way valves on the user points.

The installation of 3-way valves on the furthest user points also provides for greater thermal flywheel, which enables limiting the capacity of the buffer tank.



Parameters relating to the pressure difference in the evaporator are set up at the factory.

If they need editing, check that the water flow rate through the heat exchanger in the unit is within the operating limits admitted in the technical catalogue.

7.3.3.1 Editing the operating pressure difference in the unit

The procedure below explains how to edit the factory value.

- go to the main screen and press the arrow right button;
- click the arrow down button to select the “Flowzer” function and then press “Enter” to confirm;
- Press the button “SET” to access the screen where the setpoint difference value is set up: use the “arrow” buttons to move and select the parameter to be edited.
- Press “ENTER” to enable the edit window.
- Use the “arrow” buttons to set the new value and press “ENTER” to confirm.

7.3.4 Flowzer VD

The “VD” function is used to set the speed of the pump to keep constant the pressure difference between the delivery and return lines in the system.

If the pressure difference is kept constant at the ends of the system, the speed of the pump is set automatically in such way that the desired flow rate is preserved as the load varies.

If the demand from the system is reduced, the pressure difference increases and the controller offsets it by reducing the pump speed, which results in energy consumption saving.

The controller in units featuring a heat pump offers the possibility to set a pressure difference for operation in cooling mode and a pressure difference for operation in heating mode, which helps the unit adapt to seasonal requirements.

This function requires the installation of pressure probes on the system delivery and return lines.

Probes are supplied in a kit and installation is to be performed as instructed in the “System components” section. The connection is to be made as shown in the wiring diagram.

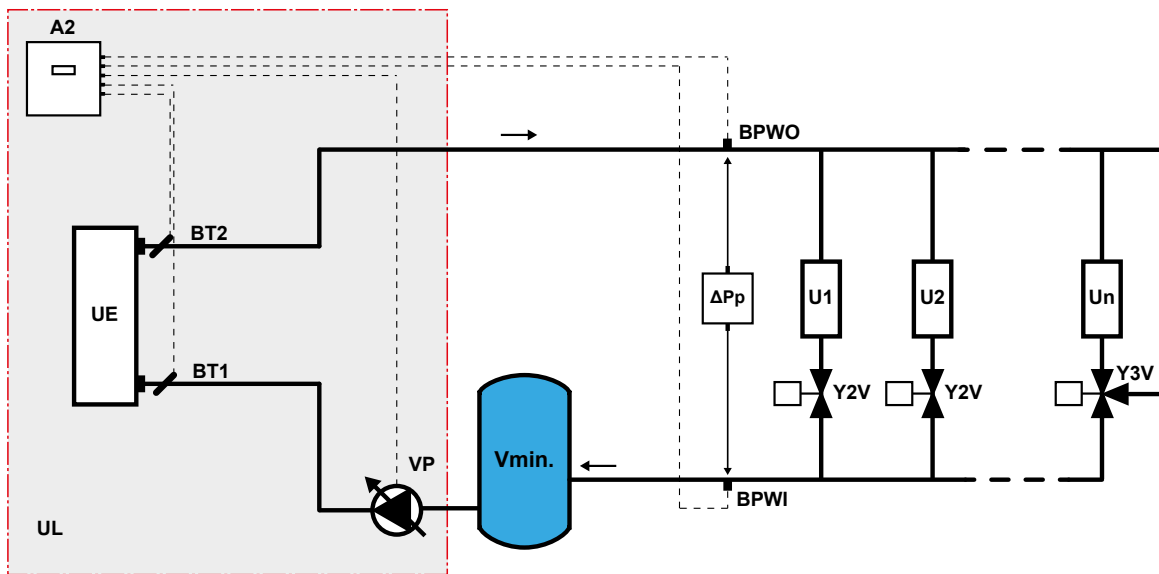

The abbreviations present in the diagram indicate:

- A2 = cooling unit controller
- BT1 = unit input temperature sensor
- BT2 = unit output temperature sensor
- EU = heat exchanger in cooling unit
- VP = variable flow pump
- BPWO = system/plant delivery pressure sensor
- BPWI = system/plant return pressure sensor
- ΔPp = pressure difference at the ends of the system
- U1, U2 .. Un = points of use present in the system/plant
- Y2V = 2-way valve servo controls

-
- Y3V = 3-way valve servo controls
 - V_{min} = minimum water volume in the system/plant
 - UL = limit of the supply.

This type of system requires that the min. water flow rate is also guaranteed when there is no load. This is made possible through the installation of 3-way valves on the user points.

The installation of 3-way valves on the furthest user points also provides for greater thermal flywheel, which enables limiting the capacity of the buffer tank.

7.3.4.1 Editing the operating pressure difference in the unit

The procedure below explains how to edit the factory value.

- go to the main screen and press the arrow right button;
- click the arrow down button to select the "Flowzer" function and then press "Enter" to confirm;
- Press the button "SET" to access the screen where the setpoint difference value is set up: use the "arrow" buttons to move and select the parameter to be edited.
- Press "ENTER" to enable the edit window.
- Use the "arrow" buttons to set the new value and press "ENTER" to confirm.



Check that the flow rate through the heat exchanger in the unit, including without thermal load, is within the operating limits admitted in the technical catalogue.

7.3.4.2 Checking of system flow rate

After entering the setpoint difference, we recommend checking that the pump is sized correctly.

Check that the pump can fulfil the max. system demand as follows: open all the user points and check that the speed of the pump is such as to achieve the stored setpoint difference.

If the setpoint difference fails to be achieved, a new pump must be selected.

Close all the user points in the system and check that the water flow rate through the unit falls within the limits admitted in the technical catalogue.

If this condition is not met, replace the 2-way valves in the system with 3-way valves until the min. flow rate is achieved.

7.3.5 Flowzer VFPP

The “VFPP” function is designed to control variable flow systems to the primary circuit.

The system keeps stable the difference in the water pressure and temperature in the system delivery line as the demand changes.

The water flow rate and temperature are independent variables and not directly connected.

Control of the “single pump in the system” provides for the necessary flow rate/head, while control of the cooling capacity provides for the correct temperature.

If the demand from the system is reduced, the pressure difference increases and the controller offsets it by reducing the pump speed, which results in energy consumption saving.

The water flow rate in the primary circuit is always set within the limits required for correct operation of the cooling unit.

The controller in units featuring a heat pump offers the possibility to set a pressure difference for operation in cooling mode and a pressure difference for operation in heating mode, which helps the unit adapt to seasonal requirements.

This function requires the installation of pressure probes on the system delivery and return lines in addition to a bypass valve.

The bypass valve and the probes are supplied in a kit. They must be connected as shown in the wiring diagram.

For this function to be applied correctly, the hydraulic circuit must be made as shown in the diagram below.

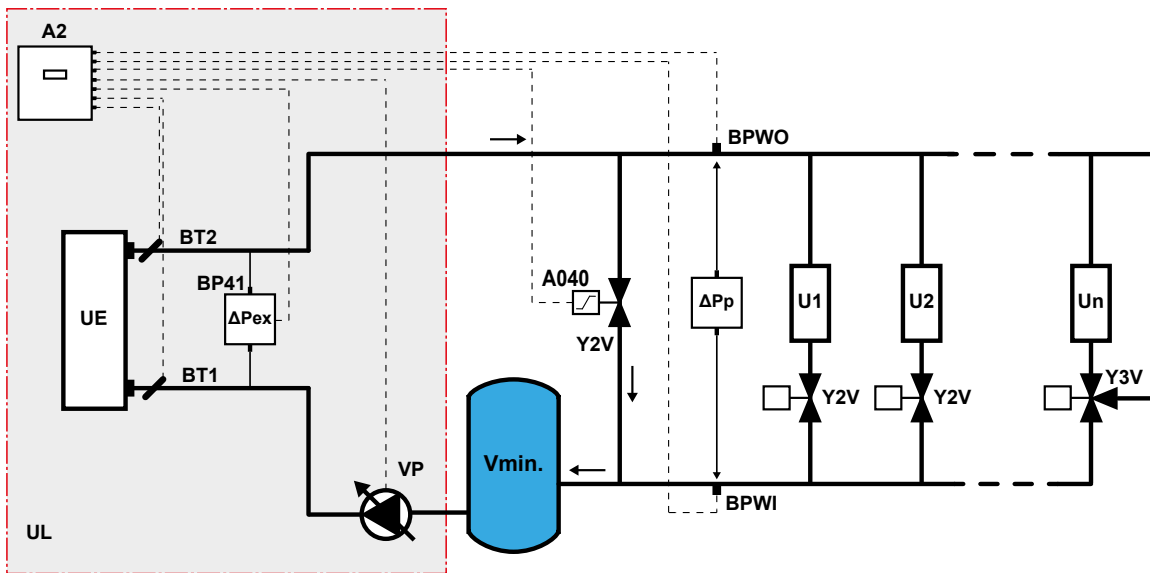

The abbreviations present in the diagram indicate:

- A2 = cooling unit controller
- BT1 = unit input temperature sensor
- BT2 = unit output temperature sensor
- EU = heat exchanger in cooling unit
- BP41= differential pressure sensor;
- ΔP_{ex} = pressure difference at the ends of the unit;
- VP = variable flow pump
- A040 = 2-way bypass valve servo control
- BPWO = system/plant delivery pressure sensor
- BPWI = system/plant return pressure sensor
- ΔP_p = pressure difference at the ends of the system
- U1, U2 .. Un = points of use present in the system/plant
- Y2V = 2-way valve servo controls
- Y3V = 3-way valve servo controls

- V_{min} = minimum water volume in the system/plant
- UL = limit of the supply.

7.3.5.1 Setting the operating setpoint difference

Below is the procedure to be followed to edit the pressure difference setpoint.

- go to the main screen and press the arrow right button;
- click the arrow down button to select the "Flowzer" function and then press "Enter" to confirm;
- Press the button "SET" to access the screen where the setpoint difference value is set up: use the "arrow" buttons to move and select the parameter to be edited.
- Press "ENTER" to enable the edit window.
- Use the "arrow" buttons to set the new value and press "ENTER" to confirm.

7.3.5.2 Instructions for system start-up

In addition to the instructions provided in the section on unit "Commissioning", a check is required in systems featuring the "VFPP" function for correct sizing of the pumps in order to ensure proper setting and increased efficiency under low load conditions.

Correct sizing is obtained with checking of pump operation at the rated flow rate of the system/plant and at the minimum flow rate.

For these checks, it is not necessary for there to be a load demand because these are checks of the hydraulic system.

7.3.5.3 Checking the rated flow rate

Open all the system/plant user points present and wait for about ten minutes until the system reaches an equilibrium.

The following situations can occur:

1. The ΔP_p value reaches the required setpoint within the set differential; the ΔP_{ex} value is within the value range set in parameters "PA22" and "PA55"; the pump works at a percentage higher than 80%; the system can be considered well calibrated at its nominal operating point. But, if in this condition, the pump has to work at below 80%, the pump is oversized for the specific system/plant and should therefore be re-selected, otherwise its control margin would be excessively reduced with consequent reduction in efficiency of the variable flow rate system.
2. The ΔP_p value reaches the required setpoint within the set differential, but the ΔP_{ex} value is higher than the value stored in parameter "PA55". This means that the water flow rate calculated by the system is higher than the required rated flow, as a result of which the ΔP_p setpoint must be reduced until the ΔP_{ex} parameter falls within the value range set in parameters "PA22" and "PA55". In this new condition, the pump must work at a percentage higher than 80%, in which case the check can be considered successfully finished. But, if in this condition, the pump has to work at below 80%, the pump is oversized for the specific system/plant and should therefore be re-selected, otherwise its control margin would be excessively reduced with consequent reduction in efficiency of the variable flow rate system.
3. The ΔP_p value reaches the required setpoint within the set differential, but the ΔP_{ex} value is lower than the value stored in parameter "PA22". This means the water flow rate calculated by the system is lower than the required rated flow, as a result of which the ΔP_p setpoint must be increased until the ΔP_{ex} parameter falls within the value range set in parameters "PA22" and "PA55". In this new condition, the pump must work at a percentage higher than 80%, in which case the check can be considered successfully finished. But, if in this condition, the pump has to work at below 80%, the pump is oversized for the specific system/plant and should therefore be re-selected, otherwise its control margin would be excessively reduced with consequent reduction in efficiency of the variable flow rate system.
4. The ΔP_p value fails to reach the required setpoint. The pump will operate at 100% (the controller increases the pump speed to reach the setpoint value stored in parameter ΔP_p). In this case, the value of the ΔP_p setpoint must be reduced in order for the pump speed to exceed 80% and for the value stored in ΔP_{ex} to be correct, ranging between the values set in parameters "PA22" and "PA55". If possible, you can calibrate/partially close the user points and then repeat the test.
5. The ΔP_p value fails to reach the required setpoint. As in the previous case, the pump will necessarily operate at 100%, but the value in ΔP_{ex} is smaller than the value in parameter "PA22". This means the pump is insufficient to overcome the total head losses of the system, and therefore, if there are no margins for improvement (partially closed valves/gate valves, clogged filters, etc.), the pump must be replaced with one having a higher head.

Letter “L” appears in the first screen of the Flowzer menu to indicate that the value ΔP_{ex} is lower than the setpoint stored in parameter “PA22”.

If the value ΔP_{ex} is higher than the setpoint stored in parameter “PA55”, letter “H” appears in this position, instead of “L”.

IN 12.2 °C	Status Regulation	Flowzer VFPP
OUT 7.1 °C	Set point 130.0 kPa	Zone ▼
Plant diff. pressure	90.0 kPa	
Exchanger Pressure	8.0 kPa	82 % 30 %
ESC		SET

7.3.5.4 Checking the minimum flow rate

Progressively close all the user points and check that the pump speed slows progressively.

If the pump speed fails to be reduced, the reason could be an excessive number of 3-way valves (for example, “Un”-type user points shown in the reference hydraulic circuit).

In this case, you can check with the installer/design engineer whether it is possible to progressively choke the third port of the 3-way valve (bypass port) to obtain a progressive reduction in pump speed and consequent increase in total efficiency of the variable flow rate system.

7.3.6 Flowzer VPS

The “VPS” function modulates the flow rate to the primary circuit following the flow of the secondary circuit, taking as reference the difference in the water temperature measured between the outlet of the primary circuit and the bypass pipe.

Water flow rate control in the primary circuit always takes place within the limits set for correct operation of the refrigerant unit.

If the flow in the secondary circuit is reduced, so is the flow in the primary circuit, which results in energy consumption saving.

This function requires the installation of a temperature sensor on the bypass pipe. The sensor must be connected as shown in the wiring diagram.

For this function to be applied correctly, the hydraulic circuit must be made as shown in the diagram below.

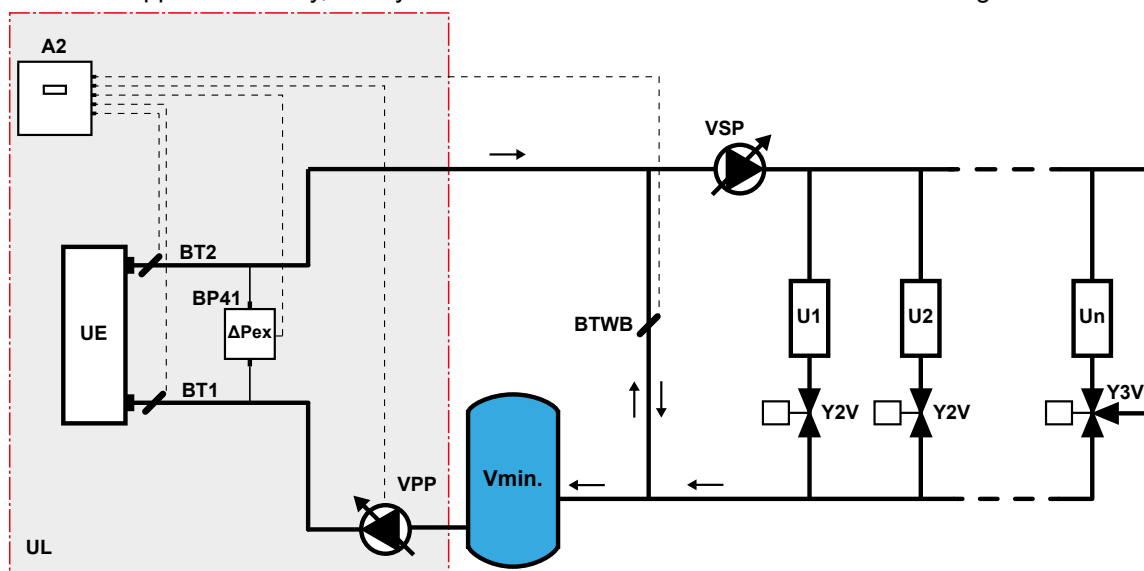

The abbreviations present in the diagram indicate:

- A2 = cooling unit controller
- BT1 = unit input temperature sensor
- BT2 = unit output temperature sensor
- EU = heat exchanger in cooling unit
- BP41= differential pressure sensor;
- BTWB = temperature sensor on bypass pipe;
- U1, U2 .. Un = points of use present in the system/plant
- Y2V = 2-way valve servo controls
- Y3V = 3-way valve servo controls
- Vmin = minimum water volume in the system/plant
- UL = limit of the supply.

When making the hydraulic circuit as shown in the diagram, attention must be paid to the following:

- the bypass pipe must be of the same diameter as the connections of the unit;
- the temperature sensor must be installed as instructed in the section “System components”;
- To give greater reactivity to the system/plant and to reduce the capacity of the tank, the points of use furthest away from the refrigerant unit must be fitted with a three-way instead of a two-way valve.
- the tank must supply the amount of water required to ensure that the min. volume specified in the unit installation manual is circulated, even with the user points off.

7.3.6.5 Setting the operating setpoint difference



The value stored in the operating temperature difference parameter, as set at the factory, is the result of our experience with different systems.

An incorrect value will eventually reduce the setting efficiency.

Below is the procedure to be followed to edit the temperature difference setpoint.

- go to the main screen and press the arrow right button;
- click the arrow down button to select the “Flowzer” function and then press “Enter” to confirm;
- Press the button “SET” to access the screen where the setpoint difference value is set up: use the “arrow” buttons to move and select the parameter to be edited.
- Press “ENTER” to enable the edit window.
- Use the “arrow” buttons to set the new value and press “ENTER” to confirm.

7.3.6.6 Instructions for system start-up

In addition to the instructions provided in the section on unit “Commissioning”, a check is required in systems featuring the “VPS” function for correct sizing of the pumps in order to ensure proper setting and increased efficiency under low load conditions.

Correct sizing is obtained with checking of the flow rate in the bypass and in the primary circuit.

The bypass (or hydraulic circuit breaker) compensates any flow rate differences between the primary circuit where the VPS system management is present and the secondary circuit where management is to be provided by the customer.

To have an optimal delivery temperature in the system/plant and maximum efficiency, the flow rate in the primary circuit must be the same as that in the secondary circuit and therefore no water must pass through the bypass.

In the case of system/plant operating conditions with a flow rate lower than 50% of the rated flow rate of the refrigerant unit, the primary circuit water will go through the bypass.

For correct operation of the unit, even when there is no secondary circuit demand, 50% of the flow rate must be ensured in the primary circuit.

This check requires the system to be loaded.

7.3.6.7 Checking the rated flow rate

The operations to carry out are as follows.

1. start the VPS system on the primary circuit;
2. start the secondary circuit at the rated flow rate;
3. allow the system to reach a steady state (stable speed/frequency of the pump).

The check can be considered successful if at steady state the pump of the primary circuit operates at a stable speed above 80% and the pressure difference at the ends of the unit is within the value range set in parameters “PA22” and “PA55”.

On the other hand, if the value ΔP_{ex} is higher than the setpoint in parameter “PA55”, the rated flow to the secondary circuit is higher than the rated flow of the unit.

In this condition, the possibility should be investigated to reduce the flow rate to the secondary circuit in order to bring the pressure difference at the ends of the unit below the setpoint in parameter “PA55”.

If, at steady state, the pump of the primary circuit works at a stable speed below 80%, the pump is oversized for the specific system/plant and it should therefore be re-selected, otherwise its control margin would be excessively reduced with consequent reduction in efficiency of the variable flow rate system.

Finally, if the pump in the primary circuit at steady state operates at 100% and the value ΔP_{ex} is lower than the setpoint in parameter “PA22”, the pump in the VPS system cannot overcome the head losses of the primary circuit. In this case, if there is no margin for improvement on the primary circuit (partially closed valves/gate valves, clogged filters, etc.), the pump must be replaced with one having a higher head.

Letter "L" appears in the first screen of the Flowzer menu to indicate that the value ΔP_{ex} is lower than the setpoint stored in parameter "PA22".

If the value ΔP_{ex} is higher than the setpoint stored in parameter "PA55", letter "H" appears in this position, instead of "L".

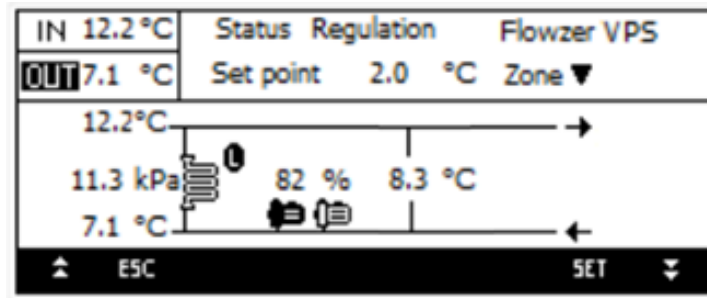

7.4 Calibration of safety components



Any work on the unit must be carried out by qualified authorised personnel. Incorrect calibration values can cause serious damage to the unit and harm people.

The control and safety equipment is calibrated and tested in the factory before the unit is shipped.

However, after the unit has been started, the safety devices must be checked (only the high and low pressure switches).

The checks must be carried out as described in the "Periodic checks" chapter.

The calibration values are shown in the table

Unit control	Parametric		Programmable		-
	Activation set point	Differential	Activation set point	Differential	Reset
Control and safety components	40.5 barg	7,5 barg	40.5 barg	7,5 barg	Manual
High-pressure switch	4,5 barg	1,5 barg	-	-	Automatic
Low-pressure switch	2,5 barg	1,0 barg	-	-	Automatic
Low pressure switch (for brine kit / LE)	45 barg	-	45 barg	-	-
High pressure safety valve (where present)					

7.5 Checks during operation

With the circuits operating at 100% and stable at working conditions near the nominal ones, check:

- that the electrical absorption of the unit is close to the data shown in the wiring diagram. Considerably different values may be due to the reduced capacity operation of the unit, at working conditions very different from nominal ones, or to the malfunctioning of one or more components.
- that the difference in water temperature seen between the inlet and outlet of the unit falls within the allowed range given in the Technical Catalogue.
- Higher values indicate that there is a reduced flow rate of water through the unit. In this case, it is necessary to check for closed or partially closed shut-off devices in the hydraulic circuit and check the characteristics of the pumps and that they are working correctly.
- Lower values indicate that the water flow rate through the unit is too high. In this case, the water flow rate through the system must be reduced by acting on the control switch (if any) of the pumps or by partially closing the shut-off device placed at the outlet of the unit.
- that the difference between the condensing temperature of each circuit and the air temperature is less than 25°C;
- If it is higher, check that all the fans involved are turning correctly and that there are no parts obstructing the condensing coil.
- the superheating value of the suction gas. The optimal value must be between 4 and 7°C;
- the subcooling value of the liquid leaving the condenser. The optimal value must be between 5 and 10 °C.

7.6 Alarms and malfunctions

Possible malfunctions will trigger the protective devices and safety devices of the unit before serious faults occur. All the “warnings” and “alarms” are recorded in the memory of the control and displayed on the display of the unit.



Before resetting an alarm, the cause that triggered it must be found and eliminated.

An alarm going off repeatedly quickly leads to serious damage to the unit.

Refer to the manual of the control for the alarms and warnings that appear on the display of the unit.

In case of anomalies not handled by the control panel, refer to the following troubleshooting section.

This troubleshooting section does not include causes due to deliberate work or tampering or particularly serious malfunctions, for which a thorough analysis is necessary.

7.6.1 General troubleshooting

SYMPTOM	LIKELY CAUSE	POSSIBLE SOLUTION
The unit does not start, the display is off.	No mains voltage.	Check that the main disconnect switch is in the “ON” position. Check for voltage in the power supply line.
	No voltage to the auxiliary circuit.	Check that the protective devices upline and downline of the transformer of the auxiliary circuit are undamaged. Reset the triggered protective device after eliminating the cause that triggered it
The unit does not start, the display is off, the control is powered correctly.	The unit is switched off from the display and the display is disconnected or not working.	Restore the connection of the display or replace it.
The unit does not start, the display is off, the control is powered correctly but the LEDs are not flashing.	The control is not working.	Replace the control.
The unit is operating normally, the display is off.	The connection of the display to the control is disconnected.	Restore the connection between the display and the control.
	The display is not working.	Replace the display.
The unit does not start, the display is on.	There is no 230V auxiliary power supply.	Check that the secondary circuit of the 230V transformer is intact.
		Check that the protective devices downline of the 230V transformer are intact.
		Check that the phase sequence is correct and that the phase sequence relay is intact.
Abnormal noises from the unit due to vibrations.	The weight of the unit is not distributed evenly on the base.	Correct the weight distribution of the unit by adjusting the height of the anti-vibration mounts.
Abnormal noises on the hydraulic pipes.	Operation of the system pump outside its performance curve with excessive water flow rate.	If it is not possible to work on the control of the pump, partially close the shut-off device on the delivery side of the unit until the nominal flow rate is restored.
		Check that the air valves are not shut off by valves.
	Presence of air in the system.	Vent the system.

SYMPTOM	LIKELY CAUSE	POSSIBLE SOLUTION
Presence of oil on the discharge of the safety valve.	Opening of the valve due to failure of the protective devices to operate.	Check that the high pressure switches are working and, if necessary, replace them. The valve must be replaced.
	Opening of the valve due to overtemperature.	Replace the valve and restore the charge.
Water leaks from the pump on first start-up	Bedding in the mechanical seal	Pressurize the pump body 2 or 3 times by closing and opening the delivery valve so as to correctly bed in the seal.

7.7 Temporary stop

The stopping of the unit for a few hours in the day “during non-working hours” or for a few days “over the weekend” is considered temporary.

The unit must be stopped using the display of the control, the external OK signal or via serial if included.

During the temporary stop, the unit must be powered correctly.

When the circulation pump is managed by the control of the unit, if the temporary stop takes place within sub-zero air temperature and the system does not have glycol fluid, make sure water circulation is guaranteed and that no taps or valves are preventing it.

If, in the previous conditions, the circulation pump is not managed by the control, the pump must always be kept running.

When the temporary stop is carried out in this way, all that needs to be done to restart the unit is to set the control to “ON”.

7.8 Stop for long periods of time

If the unit is to remain stopped for a season or for long periods of time, it is necessary to:

- turn the unit off by means of the control switch;
- disconnect the power supply using the switch / general switch of the unit;
- drain the hydraulic system (unless it contains glycol water).



During system drainage operations check that the air intakes/exhausts are open so as to prevent areas under vacuum in the hydraulic system of the unit.

This case record can in fact be traced back to the storage condition; therefore, refer to the relevant set limits.

Repeat the start-up procedure at the next restart.



If the hydraulic system is discharged during a stop of the unit, turn off the power to prevent the pump from starting, in antifreeze function, without water being present.

8 MAINTENANCE



All the operations described in this chapter must always be carried out by qualified and authorised personnel.



Before carrying out any work on the unit or accessing internal parts, make sure you have turned off the power supply to it.



The compressors and delivery pipes are very hot. Be particularly careful when working near them.



Be particularly careful when working near the finned coils as the aluminium fins are very sharp.



Do not access moving parts without guards.



In units with capacitors and/or inverters, certain components can remain live for several minutes even after having turned off the main switch.

Wait 10 minutes before working on the electrical parts of the unit.



Circuits supplied from external sources (made with orange cable) can remain live even after the power supply to the unit has been turned off.



Work on the unit only if there is sufficient lighting for the type of work to be carried out.

8.1 Adjustments

All the parameters that control the operation of the unit can be set through the user interface of the control.

Refer to the control manual should modifications be necessary, but contact the manufacturer first.

Calibrations regarding the safety of the unit cannot be modified (safety valves, high pressure switches, fuses, etc.) or are in any case protected from tampering (calibration of thermal overload protection devices, timers, etc.).

If in any case replacement becomes necessary, it is essential to use components supplied by the manufacturer (in the case of adjustable parts) or with the same sizes and characteristics (in the case of fuses).

8.2 External cleaning

The component of the unit that needs most care is the finned pack heat exchanger.

It is essential to keep it clean and free of dirt and/or deposits that can hinder or prevent air flow.

Regular cleaning of the surface of the coil is essential for the unit to work correctly and also increases the operating life of the exchanger and the unit.

Frequent and correct cleaning of the coils contributes to considerably reducing corrosion problems.



While cleaning the finned pack heat exchanger, the electrical control panel must be closed and the main disconnect switch must be locked in the "OFF" position.



Using a jet of water on the coil while it is still dirty will cause deposits and pollutants to remain inside the exchanger, which will make cleaning even more difficult. All the dirt and deposits must therefore be removed from the surface before rinsing.



For units installed in coastal or industrial areas or in areas where there are aggressive chemicals in the air, periodic rinsing with clean water is considerably beneficial and helps counter corrosive effects.



Never clean the coils with chemicals, water containing bleach or acid or basic detergents. These detergents can be difficult to rinse off and could accelerate corrosion on the joint between pipe and fin and in areas where different materials come into contact (Cu and Al).

8.2.1 Cleaning traditional finned coils in Cu/Al

Conventional pipe-fin coils can be cleaned with a vacuum cleaner or a brush with soft, non-metallic bristles.

Always clean in the direction of the fins and never perpendicularly to them. They can easily be bent and damaged.

Clean in the opposite direction to the normal air flow.

The coil can then be rinsed using only drinking water at low pressure (3-5 barg).



Rinsing must be carried out with a low pressure jet of water to avoid damaging the fins.

Never use jets of water or high-pressure compressed air to clean the coil. The force of the jet of air or water could bend the fins, with a consequent increase in aerodynamic head losses on the exchanger and lowering of the performance of the unit.

8.2.2 Cleaning the microchannel coils

Microchannel coils must be cleaned regularly (see Periodic checks section)

Routine and documented cleaning is a necessary condition for maintaining the warranty on the coils.



In addition to the required periodic cleaning, if the unit is used seasonally, we strongly recommend cleaning the microchannel coils at the end of seasonal use, so that no residues remain on the coils, and then again before starting the unit.

The coils can be cleaned with a high-pressure jet of water by strictly following the instructions below:

- before using the jet of water, remove extraneous objects from the coil and any debris attached to its surface or stuck between the frame and the supports. We advise using a vacuum cleaner;
- clean the surface using a high pressure water cleaner, and evenly and steadily spray the coil from the bottom upwards, keeping the jet at an angle never more than 45° to the surface;
- never exceed a jet pressure of 50 bar, and always use a diffuser nozzle that is large enough (25/30°);
- keep the diffuser nozzle at least 300 mm away from the surface of the coil. It is essential to control the pressure and be careful not to damage the fins;
- use only mains water to clean the coils (if you have any doubts about the quality of the water to be used, compare it with the table shown in the "Water composition" chapter of the "Hydraulic connection" section).

Check that no residues are left on the coil after finishing cleaning.



Excessive water pressure can bend the fins, with a consequent increase in aerodynamic head losses on the exchanger and lowering of the performance of the unit, or worse, it can cause the welds between the fins and the microchannel tubes to break.

Concentrated and/or rotating jets of water are strictly prohibited.

8.2.3 Cleaning e-coated microchannel coils

Microchannel coils must be cleaned regularly (see Periodic checks section)

Routine and documented cleaning is a necessary condition for maintaining the warranty on the coils and on the e-coated treatment.



In addition to the required periodic cleaning, if the unit is used seasonally, we strongly recommend cleaning the microchannel coils at the end of seasonal use, so that no residues remain on the coils, and then again before starting the unit.

The coils can be cleaned with a high-pressure jet of water by strictly following the instructions below:

- before using the jet of water, remove extraneous objects from the coil and any debris attached to its surface or stuck between the frame and the supports. We advise using a vacuum cleaner;
- clean the surface using a high pressure water cleaner, and evenly and steadily spray the coil from the bottom upwards, keeping the jet at an angle never more than 45° to the surface;
- never exceed a jet pressure of 50 bar, and always use a diffuser nozzle that is large enough (25/30°);
- keep the diffuser nozzle at least 300 mm away from the surface of the coil. It is essential to control the pressure and be careful not to damage the fins;
- use only mains water to clean the coils (if you have any doubts about the quality of the water to be used, compare it with the table shown in the "Water composition" chapter of the "Hydraulic connection" section).
- it is very important for the temperature of the water used for rinsing to be lower than 55°C and for the water pressure to be lower than 50 barg to avoid damaging the fins of the coil. A high water temperature (in any case not above 55°C) reduces surface tension and increases the ability to remove dirt and chlorides.

Check that no residues are left on the coil after finishing cleaning.



Excessive water pressure can bend the fins, with a consequent increase in aeraulic head losses on the exchanger and lowering of the performance of the unit, or worse, it can cause the welds between the fins and the microchannel tubes to break.

Concentrated and/or rotating jets of water are strictly prohibited.

8.3 Internal cleaning

It is essential to keep the installation site clean and tidy for correct maintenance of the unit and to keep it in good working order.

8.3.1 Cleaning the unit

Keep the inside of the electrical control panel and (where present) the compressor compartment clean.

After working on the unit, always clean the electrical control panel of any work remnants and extraneous components.

Restore the safety devices and protective devices that had to be removed in order to carry out the work.

Use a vacuum cleaner to eliminate small objects, work remnants and/or any dust.



Do not use compressed air

If you have to carry out work on compressors inside the compartment, before closing it again, check that the electrical box of the compressor is closed correctly and that any refrigerant circuit valves are in the correct state, and make sure you do not leave any materials inside the compartment.

8.3.2 Cleaning the plate heat exchangers

Thanks to the generally very high level of turbulence, in plate heat exchangers, a self-cleaning effect takes place in the channels.

However, in some applications the tendency to scaling and/or the formation of deposits in the heat exchanger can be very high (e.g. use of very hard water at high temperatures).

An increase in head losses on the hydraulic circuit and a decrease in temperature difference between water inlet and outlet, are a sign that the exchanger is becoming fouled.

In such cases, the heat exchanger can always be cleaned by circulating an in-situ cleaning fluid (CIP).



When carrying out the operations described here, adopt all the technical and organisational measures provided for by workplace safety laws and regulations; use the personal protective equipment in accordance with the instructions in the safety data sheets for the chemical products used.

Also, all technical and organisational measures for waste water treatment must be applied in accordance with current environmental laws and regulations.

To reduce the extent of scaling and residues, use a 5% solution of oxalic acid $(\text{COOH})_2$ at 20°C as washing fluid: cleaning with acid solution must be carried out for no longer than 15 minutes.

After finishing cleaning with acid detergent solutions, use a 2% solution of sodium bicarbonate (NaHCO_3) at 20°C to neutralise the acid solution.

The flow rate of the acid and basic solution must be at least 1.5 times the operating flow rate with reverse circulation mode. Then wash with plenty of clean soft water until all traces of acid and basic solution have been removed from the heat exchanger. Any traces of acid or basic fluids left inside the heat exchanger can cause serious damage to property and people.



If it is thought that the exchangers will need to be washed regularly, installing CIP valves in the hydraulic circuits will make this operation easier.

8.4 Periodic checks

Carry out periodic checks to make sure the unit is working correctly:

OPERATION	RECOMMEN- DED FREQUEN- CY
Check the operation of all the control and safety equipment as described previously.	Monthly
Check the tightness of the electrical terminals in the electrical control panel and in the terminal boards of the compressors. The moving and fixed contacts of the contactors must be cleaned periodically and should be replaced whenever they show signs of deterioration.	Monthly
Check the refrigerant charge through the liquid sight glass.	Monthly
Make sure there are no oil leaks from the compressor.	Monthly
Make sure there are no water or water/glycol mixture leaks in the hydraulic circuit.	Monthly
If the unit is to remain out of service for a long time, drain the water from the pipes and the heat exchanger. This operation is necessary if ambient temperatures lower than the freezing point of the fluid used are expected during the time it is to remain stopped.	Seasonal
Check the filling of the water circuit.	Monthly
Check that the differential water pressure switch, or the flow switch (where present), is working correctly.	Monthly
Check the crankcase heaters of the compressors.	Monthly
Clean the metal filters in the hydraulic pipes.	Monthly
Clean the finned coil by following the instructions in the "External cleaning" section according to the type of coil installed	3 months
Clean the air filters	Monthly
Clean the ventilation filters of the electrical control panel.	Monthly
Carry out the defrosting test (only for heat pump units).	Monthly
Check the moisture indicator on the liquid sight glass (green = dry, yellow = wet). If the indicator is not green, as indicated on the sight glass sticker, replace the filter.	4 months
Check the condition, fixing and balance of the fans.	4 months
Check that the noise emitted by the unit is normal.	4 months
Test performed to check correct operation of the refrigerant leak detection sensor and its safety chain connected downline	Yearly
Calibration of the refrigerant leak detector sensor	Every 3 years
Replacement of the refrigerant leak detector sensor	Every 5/6 years



This planning refers to an average installation; there could be installations in which it may be necessary to increase the frequency of some checks.



Current legislation may require considerably longer intervals on periodic checks than the recommended ones, also in reference to the safety devices installed and to the refrigerant charge present, without causing the warranty on the unit to be voided.

8.5 Unscheduled maintenance

After correctly starting-up and carrying out the relevant checks, the units normally do not need any intervention by the customer service in order to check the charge of the refrigerant gas.

8.5.1 Special work

With use of the unit, particular situations may occur that require work to be carried out promptly.



Even in an emergency, work on the unit must be carried out by skilled personnel in safe conditions.

The presence of oil on the unit, on the pipes or on parts of the unit can be a sign of gas leaks.

Repair the leakage point and restore the charge of refrigerant gas.

In the case of small oil leaks, clean the dirty parts with absorbent cloths, otherwise recover the leaked oil with absorbent sheets. In any case, the material used must be disposed of in accordance with current rules and regulations.

Check whether it is necessary to restore the oil charge.

In the case of spillage of the water and glycol mixture of the system, stop the operation of the unit and immediately stop the supply by closing the valves to isolate the leaking part.

Prepare suitable means for containing the spillage (absorbent rolls, cloths, sheets).

As far as possible, recover the liquid with a wet vacuum cleaner.

In the event of environmental damage that will require reclamation work, inform the relevant authorities.

The recovered liquid and the material used must be disposed of in accordance with current rules and regulations.

9 DECOMMISSIONING

With reference to the European waste management directive, we inform you of the following:

- The owner of electrical and electronic equipment (EEE) is obliged not to dispose of it as non-separated municipal waste, and must dispose of it via separate collection through public or private waste collection systems as required by local regulations.
- The owner can return EEE to the dealer at the end of its life when purchasing equivalent new equipment.

This EEE may contain hazardous substances such as refrigerant gases, lubricating oils and accumulators or other materials, and improper or incorrect disposal of them may have adverse effects on human health and the environment.

Incorrect disposal of them also entails penalties as provided for by local regulations.

The symbol shown on the equipment, which indicates separate collection of EEE, is a crossed out wheellie bin accompanied by a solid horizontal bar and identifies that it was put on the market after 13 August 2005.

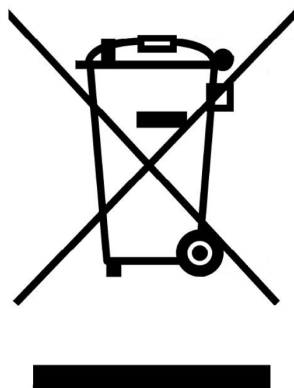

Page intentionally blank

Page intentionally blank

Page intentionally blank

